

Winter 1991

Information Technology and Wealth: Cybernetics, History and Economics

Elin Whitney-Smith
Old Dominion University

Follow this and additional works at: https://digitalcommons.odu.edu/emse_etds

 Part of the [Economic History Commons](#), [Science and Technology Studies Commons](#), and the [Systems Engineering Commons](#)

Recommended Citation

Whitney-Smith, Elin. "Information Technology and Wealth: Cybernetics, History and Economics" (1991). Doctor of Philosophy (PhD), dissertation, Engineering Management, Old Dominion University, DOI: 10.25777/b24g-b673
https://digitalcommons.odu.edu/emse_etds/162

This Dissertation is brought to you for free and open access by the Engineering Management & Systems Engineering at ODU Digital Commons. It has been accepted for inclusion in Engineering Management & Systems Engineering Theses & Dissertations by an authorized administrator of ODU Digital Commons. For more information, please contact digitalcommons@odu.edu.

**INFORMATION TECHNOLOGY AND WEALTH:
CYBERNETICS, HISTORY AND ECONOMICS**

by

Elin Whitney-Smith
B.A. June 1975, Rutgers University,
M.S. June 1985, San Jose State University

Dissertation submitted to the Faculty of
Old Dominion University in Partial Fulfillment of the
Requirement for the Degree of

DOCTOR OF PHILOSOPHY
ENGINEERING MANAGEMENT

OLD DOMINION UNIVERSITY
December, 1991

Approved by:

Laurence Richards (Director)

ABSTRACT

INFORMATION TECHNOLOGY AND WEALTH: CYBERNETICS, HISTORY AND ECONOMICS

Elin Whitney-Smith
Old Dominion University
Director: Dr. Laurence Richards

Capitalism developed where and when it did because there was high information access. There was high information access because of a major advance in information technology - the press. Where the technology was not controlled by the "powers that be" there was economic growth and a shift in the entire social structure. Where it was controlled there was no structural change and there was economic ruin. The development of capitalism is a major step change in economic growth. It is also a major change in the way people organize themselves into groups.

Major step changes in the growth and in the organization of cultures are found to be related to the introduction and use of information technology. The limit to growth is the limit of effective use of information or the variety limit. Economies are able to grow once the variety limit is raised. Information technology allows people to increase their individual variety in relation to the amount of information processed. This increase in individual variety allows the entire society to grow.

Where there is high access to information through technology there is much growth and where there is less information access through control of technology there is less economic growth. When a high access economy is in competition for resources with a low access economy the high access economy will be more economically successful.

A causal loop model is developed from a rich picture of the phenomena. The model is applied back to the press and forward to the telegraph and telephone and used to predict the impact of the current information revolution.

One of the implications of information technology is that it allows people to model things better. This, in turn, implies that the perception of reality is dependent on the ability of the implications of modeling a technology which is concerned with modeling are explored.

BIOGRAPHY

Elin Whitney-Smith

I have taught variety of subjects to a variety of populations including cybernetics to graduate students, living skills to autistic and developmentally delayed adults, English to the foreign born, poetry workshops for women, and economics to undergraduate engineers.

My work experience is also varied including: raising six children, consulting to the financial community, and the health services industry, newspaper reporting, commercial fishing, driving a commuter bus in New York City, doing field and laboratory work in archaeology.

Out of these varied life experiences and interests I have developed a unique approach to the analysis of information technology and economic and cultural change. I maintain that perceptual change is a necessary factor for economic development, and perceptual change is a result of technological change, because people perceive their world through the interface of technology.

Because of this, I believe that a major challenge to Engineering Management, as a discipline, is understanding how to use technology to change perceptions to allow economic development.

I hold a B.A. in anthropology with an emphasis in archaeology from Livingston College, Rutgers University, a M.S. in cybernetic systems from San Jose State University.

TABLE OF CONTENTS

	PAGE
LIST OF FIGURES.....	iii
PREFACE.....	v
1. INTRODUCTION.....	1
2. THE PRINTING PRESS.....	45
3. THE PRESS AND THE RISE OF CAPITALISM.....	64
4. THEORIES OF THE RISE OF CAPITALISM.....	88
5. CYBERNETICS, INSTABILITY, AND GROWTH	
INTRODUCTION TO THE MODEL: PART 1.....	122
SUPERSYSTEM BEHAVIOR.....	127
INTRODUCTION: PART 2.....	160
SYSTEM AND INDIVIDUAL BEHAVIOR.....	165
APPLICATIONS.....	173
6. ECONOMIC DEVELOPMENT AND CRISIS.....	175
7. ELECTRIC INFORMATION REVOLUTION.....	206
8. CONCLUSION AND IMPLICATIONS.....	241
META-STATEMENT.....	259
BIBLIOGRAPHY.....	267
APPENDICES	
A. INCREASE IN NATURAL UNIT SIZE.....	287
B. DEFINITIONS: REDUNDANCY, CONNECTANCE.....	291
C. REDUNDANCY AND CONNECTANCE: CAUSE OF SYSTEMS GROWTH.....	295

LIST OF FIGURES

FIGURE	PAGE
1. Positive feedback loop.....	13
2. Graph of predator prey-population relations.....	14
3. Agriculture and population, positive feedback.....	19
4. Population control in a manor economy.....	33
5. Correcting feedback in printed books.....	56
6. Relations: Protestantism, literacy and self-reliance.....	78
7. Dynamics of map-correcting feedback.....	97
8. Competition optimizes production.....	117
9. Classic control system: growth and investment.....	129
10. Graph: system behavior over time.....	131
11. System with lag time included.....	133
12. Graphs: system behavior with lags.....	134
13. Innovation controls amount of growth possible.....	135
14. Information access controls innovation.....	137
15. Information access: a function of known and the number of knowers.....	138
16. Information technology completes a positive loop.....	140
17. Comparison of non-simultaneous and simultaneous impact.....	142

FIGURE	PAGE
18. Simultaneousness and the Soros effect.....	145
19. Perceived threat to the status quo.....	147
20. Relationships after the first phase.....	148
21. Strong threat.....	149
22. Little threat.....	151
23. Graph: information controlled non-competitive context.....	153
24. Graph: information controlled competitive context.....	155
25. Graph: information not controlled competitive context.....	156
26. Graph: most growth occurs before the limit is reached.....	158
27. Graph: Effect of a raised limit on growth.....	159
28. Time line, information technology impacts and economic downturns.....	214
29. Impact of literacy and economic participation for men and women, positive feedback.....	240

Preface

Science is like a mystery novel. In the novel the detective has to reason to the "who done it" on the basis of the evidence and knowledge of human nature and the world (Einstein & Infield, 1938). A good mystery has clues which the reader does not take into account as clues, until the detective explains at the end of the book. The same is true for history. There are hints which do not seem to be clues, or do not seem to be important, without the right explanation, theory or model.

When I started to think about this work I had a dimly perceived idea of how major shifts between cultures worked. It was based on the insight or "aha" that hunter/gatherers based their survival on their access and use of information. They lived in information intensive societies and used material goods to cement social relations. In contrast to that way of life, from the invention of agriculture on, people have based their security on access to material goods and have used information to increase their access to those goods.

This simplistic dichotomy guided my research. I reasoned that if this was true - that information and material goods are a kind of complementary relation - then I should find major shifts in people's relation to material reality when information relations changed and vice versa.

This led me in two major directions. First to an investigation of the instances of major information technology change and second to an investigation of the theories surrounding the invention of agriculture. This in turn led to studying in two doctoral programs: one which specializes in the study of evolutionary and ecological systems - Geobiology, at George Washington University - and one which specialized in the relation between technology and social systems - Engineering Management at Old Dominion University.

The relationship between my experiences of these two programs of study has guided my approach to science and method. In this work I have replicated my experience as to how science proceeds in evolutionary biology as a guide for how to proceed in history and social science. I have done this partially because I think that social science has become enamored of mathematics and statistics and has lost sight of what it means to do science and partially because I think it is an approach which will yield good results.

The way I experience the process of science is: 1) The scientist has some notion of theory which guides her investigations. These investigations may be from a number of different angles and perspectives as she tries to refine her notions and ideas. She will probably look at what work has been done by others. 2) As the theory becomes clearer she is able to make a more formal model. 3) She uses the formal model to explain the original phenomena and to explore other related phenomena. 4) The exploration of related phenomena may lead to further refinements of the model and further insights into the original phenomena. 5) This returns the scientist to the beginning.

In this work the first four chapters are the first step. Chapter I presents a brief summary of the history of mankind and an informal model of how major shifts in social, economic and cultural paradigms occur. It is intended to focus the reader on broad similarities of the dynamics of change.

Chapter II talks about the way the pre-press world presented itself on the basis of the "clues" in the historical record in contrast to how a post-press world presented itself.

Chapter III presents the social consequences of the changes in information access brought about by the press.

Those consequences include: 1) where economic development has occurred; 2) gender and age class of participants in economic development; 3) how we define what is part of the conversation of economics and what is not.

Chapter IV is a review of what has been said by others or literature review and how that relates to economic development and the impact of the press.

Chapter V presents the formal model - the second step in the outline of how one does science above.

Chapter VI uses the formal model to look at the impact of the press and is the third step in the scheme of how to do science above.

Chapter VII is the fourth step. It uses the model to investigate electric information technology - the telegraph and the telephone. In the course of that investigation the model is found to have some misfits. Investigation of these misfits further refines the model.

Chapter VIII is the conclusion and implications. It brings us back to the beginning in the form of a meta comment on what it means to take this stance toward historical and social science research.

I believe that there are regularities in how people shift from one way of perceiving and interacting with their world to another way of perceiving and interacting. These

regularities have to do with the perception, access and circulation of information in the society and the changes in perception have real consequences and leave trails of evidence. I have written this work as an offering to the reader in support of that belief.

I have had traditional and non-traditional support from many people and I owe much to those who have helped my thinking along. Merry, Joyce, Hannah, Tina, Lady, Ardy and the cats who opened their home to me for two summers allowing me to work, live and play in their space. Bob, Marty, Lindsay, Laura, Liam, Gooba and the guinea pigs who did the same in Virginia during the school terms. The folks at Greenhill Farm and Magic Mountain who continually remind me of who I am and give unquestioning acceptance. To Howard who believed and my children for their love, thank you. To the Von Foersters, Mai and Heinz extended support above and beyond that expected of a committee member to include financial help which allowed me to keep going, I owe more than can be said. Finally to Christoph who is formatting my chapters as I type this, who shares the late night doubts, the early morning joys, the afternoon walks, who prepares and shares marvelous meals and, and whose ideas have added to every chapter (especially V) my deepest gratitude.

In memory of my mother Dorothy Elinor Hanson
and my grandmother Ella Peterson Hanson,
the first and best of my teachers.

x

Chapter I

INTRODUCTION

Assertions/ Positions

Wealth is generated through information. Those who control information, control access to wealth. Economic history can be analyzed in terms of information ownership. There have been two major information control shifts in the economic history of the west. Through understanding the dynamics of information ownership and control we can understand the dynamics of economic development. If we want to extend the benefits of wealth to third world countries and understand the differences in economic development in the west and in the east, we need to understand the dynamics of information ownership.

Introduction

Any work of scholarship goes through many stages. In this work I started looking at how the organization of

business changes with the introduction of new information technology. I planned to look at the organizational and economic impacts of the printing press, the telegraph and the telephone. I was hoping that understanding how these technologies affected the organization of business would give me some hint as to how newer information technologies; e.g. computers, FAX, and E-mail, will change our society.

In the course of researching the impacts of the press I realized that I had stumbled on an explanation for one of the major questions in economic history: what has caused the incredible wealth of the west?

I have also come to realize that the difficulty in seeing the impact of any technology is not in seeing the results but in seeing how it was before. This is because once a person's perception has been altered it is hard to "not perceive". Next time you are on a trip try to "not read" road signs or billboards as an experiment in not making a distinction.

This led me to see that the major impact of any technology is how the perceptions of the users are changed through its use. For example, few of us think of twenty miles as being far because it is only a few minutes in the car, in a world which walks on foot or at most rides a horse twenty miles is a considerable journey. Our

perception of distance has changed because of our interaction with a technology.

These problems are compounded looking at the impact of information technologies because scholars get seduced by the things which are most obvious: what the book says or when some new typographic technique appears. It is more difficult considering questions like: How does having a standard edition of a book change people's perception of reality as being standard and researchable compared with having a hand written copy which is slightly different from every other copy of the same book? Or how does the economic world change when anyone with some money can become self-educated through books instead of education being restricted to the elite?

Again, the problem is seeing the world as it was before, rather than as it is now. For example, in the pre-press world, books changed through scribal drift (Eisenstein, 1979). This is similar to the child's game of telephone where each repetition is slightly different than the last. Make the experiment of hand copying a long piece of precise text in a subject you don't quite understand, then realize that this is what happened again and again to a single piece of text before the press. This created a world in which information was not standard or stable, a

world in which one relied more on what an authority said than on what one read.

Another major problem is that information is not *stuff* like grain, or oil, or steel. I can know something and tell it to you and still have it, or I may tell it to you and you will still not have it. This seems to imply that information cannot be owned or controlled and yet I use those words repeatedly in my set of assertions. I am hoping that as I tell my story, how I mean words and the assertions at the beginning of the chapter will become clear.

This is contrary to the accepted procedure of painstakingly defining ambiguous words like information and knowledge. This is because of how I view the notions associated with these words. If pressed I can define information as "a socially constructed word we use to indicate portions of an individual's environment, with which that individual interacts, so that they may interact with that and other environments, in ways which the individual defines as better." Because I have defined information as a portion of an environment, what I am doing in writing this work is creating an environment with which you - the reader - can interact.

This lengthy and wordy procedure leaves me with the problem of defining "interact," and "environment," in the

same manner. I believe that this way of proceeding is unnecessary and unproductive: unproductive, because if I go on in this tedious manner you will become bored and stop interacting with this particular bit of the environment; unnecessary, because you already have some kind of working definition of these words and concepts, and if you continue to interact with this bit of the environment, your definition will be modified over the course of the interaction, such that you will better understand what I mean. Further, although we can both quibble about the niceties of the definition if we want to actually say something like, "pass the butter," we can and do - language works. Thus, I will confine my definitions to the few technical terms and notions from cybernetics which may be unfamiliar to the general reader.

Cybernetic Notions and Terms

The notion of deviation amplification or positive feedback refers to a condition where an increase in one variable causes an increase in another variable which causes an increase in the first variable. This is exactly what happens when a microphone is placed too near a speaker. The microphone picks up ambient room noise, this is amplified by the speaker, this amplified sound is picked

up by the microphone and again is amplified, this eventually results in the high pitched squeal with which we are familiar. If this condition were to go unchecked the speaker would eventually break. This is another characteristic of a positive feedback loop - they are inherently unstable and eventually result in some change of state - a broken speaker.

Negative feedback acts to correct deviation in the system. The classical example of this is the heating system and thermostat which switches on the heating unit when the house gets colder than the desired temperature and switches it off when the house gets warmer than the desired temperature.

The notion of **variety** refers to the number of states which a system can assume. The law of requisite **variety** (Ashby, 1971c) refers to the balance of variety of a controller or regulator of a system and the variety of the system. In the thermostat example above the system has two states - too hot and too cold - for a variety of two, and the regulator - thermostat - has two responses - heater on and heater off. The regulator has the requisite variety to control the system. If we also want the humidity controlled then the thermostat does not have sufficient variety to control the system since the system is now defined to have four states - too hot, too cold, too humid

and too dry. In this example we can quantify the states of the system exactly. In social systems we can generalize the notion to give us some notions of the orders of magnitude necessary to control a system even though we cannot quantify the variety exactly. For example, if a tax collector has to keep all the tax records of his jurisdiction in his head, his variety is limited to the number he can remember, if he can use the *quipu* (the system of knots used by the Inca for record keeping) then his variety is increased such that he can keep track of a far greater number of tax records. The *quipu* is an example of an information technology (Ascher & Ascher, 1982).

Informal Model

As I tell the story of how the dynamic of cultural change works it may be useful to have some notion of what I would like you to pick out of the telling - to have some informal model of the dynamic which will be developed in this work. I am presenting the model below without explanation because I would like understanding of the model to emerge through interaction with the examples. The dynamic of change works through a four stage process:

- 1) There is an initial equilibrium condition, where needs are kept in balance with the technological capacity of the system to produce. This implies

some form of control conscious or unconscious which work as a negative feedback loop to maintain the equilibrium.

- 2) The controls which maintain the balance or equilibrium are "unstuck" creating a positive feedback cycle.
- 3) The technological carrying capacity or system limit is exceeded resulting in a crash.
- 4) There is rebuilding of a new system on the basis of a combination of old and new forms.

In order to tell the story I have to go back and try to paint a picture of how the world was perceived before the first economic revolution.

Ice Age Hunters

Imagine the last ice age, when there was ice covering much of the Northern Hemisphere, and there was tundra in New Jersey. The men and women of the times followed the herds of large herbivores: bison, caribou, and mammoth. If they were like today's hunter/gatherers (Lee & Devore, 1976; Lee, 1984) their perception of the world was that what was needed was available for the taking. They knew they lived in a world of plenty.

If they were like today's hunter/gatherers, they lived by relying on their knowledge of their environment, rather than by accumulating goods. They had no war because it hadn't been invented yet and because what they valued

most were their stories, songs and their knowledge of how the animals and plants were in the world. In such a world you cannot take the most valuable thing away from someone else because you cannot force the sharing of information. Also if you live in a world which you feel has enough for everyone there is no reason to fight. In contrast to economies based on the accumulation of material goods like grain or gold, hunter/gatherers lived in an information based economy.

Most of us would assume that the reason hunter/gatherers move around is because they have exhausted the food supply in the place they are. However, according to Lewis Binford (1978, 1983), Eskimos move from where they know there is food to the next place, because they don't know what is happening there. They are interested in knowing what is happening over the next hill. They do not move because they need to find food. They move because they want to know more. Their security lies in being able to read their environment and adjust their circumstances accordingly.

This can also be a harsh adjustment. Lee (1984) reports that amongst the !Kung San - hunter/gatherers of the Kalahari of Africa - sanctions can extend to killing a person who does not conform. The adjustment of the group to the environment may be by controlling births, by

infanticide or by dividing up the social group into larger or smaller units according to the availability of resources. This survival strategy changes the group to fit the environment rather than changing the environment to fit the social group. In order to successfully anticipate and adapt to environmental change it is necessary to rely on how well members of the group are able to read small environmental cues. Because of this reliance on "information" I call this an information-based economy.

In a world where the thing which gives a person status is their knowledge there would be a high premium placed on sharing. This is because it is in the nature of knowledge to be visible only when shared. This means that for a person to show off her knowledge she would have to tell about it. This encourages a world view where to be "cool" is to know, and to know is to share.

If the animals of the ice age behaved like today's herd caribou, they traveled vast distances in small herds, gathering together, at certain seasons, in large numbers, then breaking into small groups again. If the people were following the herds, they would meet other groups of people who had followed other groups of animals.

Large seasonal gatherings where the herd animals got together would have been good times for telling stories, singing songs, teaching new techniques and skills

and comparing experiences. For young people, it would have been a time to make new friends and find mates. Taking mates from other groups would be another way of spreading information. We could think of this as a vast information network. We know that similar beautiful leaf shaped fluted points, all the same style, have been found from Alaska to Maine to Tierra del Fuego (Mehring, 1988; Canby, 1979).

If we take modern hunter/gatherers as an example we know that they had a different perception of land use. The Indians who sold Manhattan Island for a handful of trinkets had a notion of land use which did not include the way Europeans used land. They expected Europeans to hunt and gather food and water. They had no concept of farms, towns, permanent settlements and cities. Their idea of ownership did not include the distinction of exclusive use. It is doubtful that they understood land as property. Property probably only extended to what we would call personal possessions - trinkets, clothing, tools and weapons, all of which could be carried.

The archeological record indicates that at some time during the last ice age, people in Europe started hunting using surrounds. They herded the animals into a small canyon, or through fences to a corral where they could be killed off easily. They may have started doing this because they were having a harder time finding

animals. We know there was a shift to smaller animals before the extinction of the larger animals was complete. This may have been because the habitat was contracting, because climate was changing. It may have been a response to increase in population size, or it just may have been a good idea. Regardless, this idea could have spread through the information network.

The expanded resource base, made possible by the new technique, would support larger, more sedentary, populations. If there had been population controls, they would no longer be necessary. At first, more people meant more hunters, who could kill more animals. More animals killed meant populations could expand more. The "unsticking" of the controls, which maintained the balance, would create a boom condition - a positive feedback loop (fig. 1). In the hunter - herbivore relationship, hunting pressure, combined with the affect of the contraction of habitat, could have caused the extinctions which we know occurred at the end of the ice age (Canby, 1989; Martin, 1972; Martin & Klein, 1989).

But what of the hunters? In classical predator prey relationships, the collapse of a prey species is followed by either the collapse of the predator species or an oscillation between growth and decline of both species (Holling, 1959; Huffaker, 1958) (fig. 2). The diet of

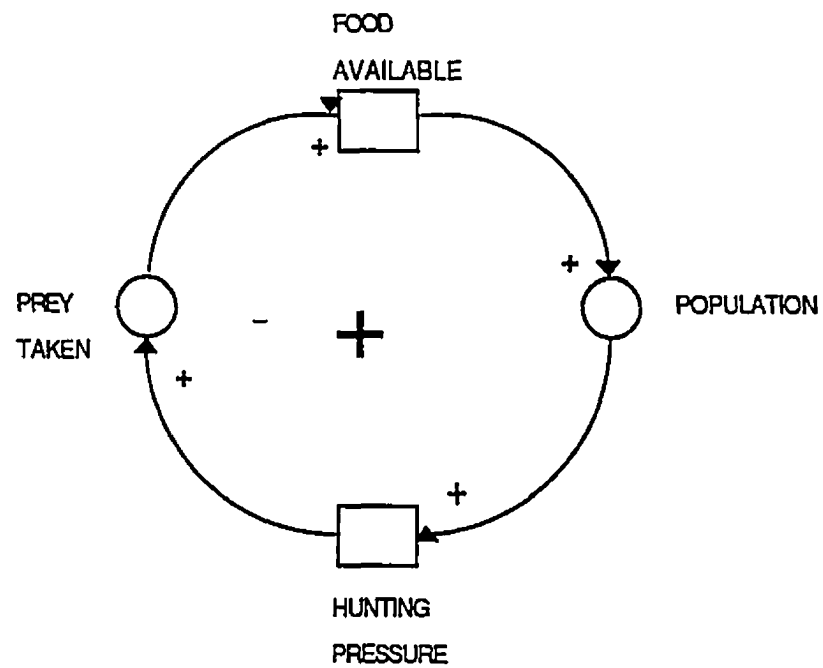

Figure 1: Positive feedback: as hunters increase there is an increase in prey killed which allows hunter populations to increase.

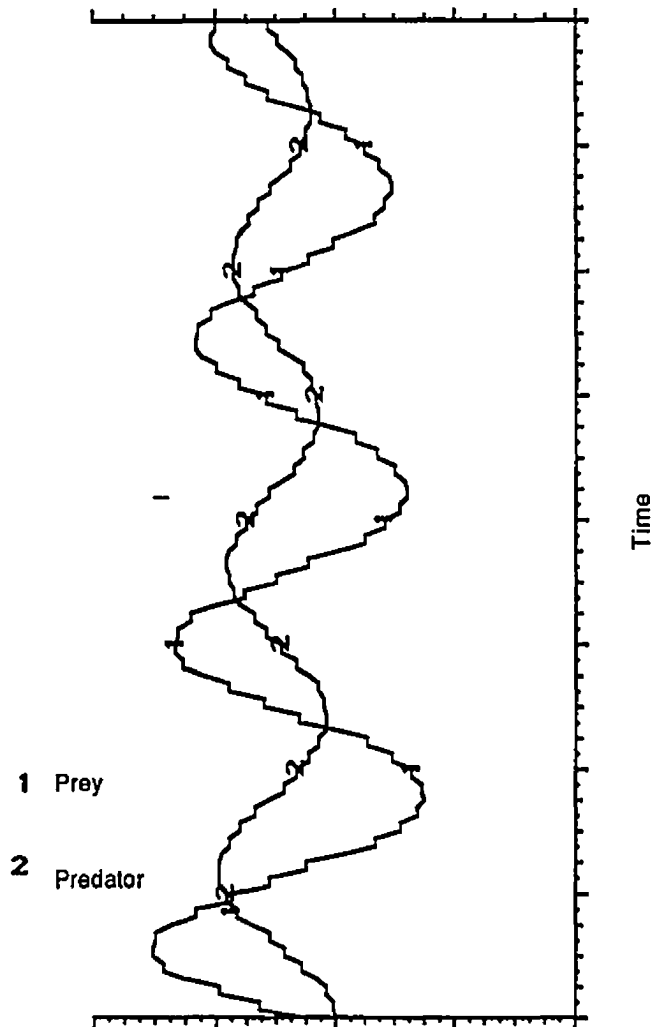

Figure 2: Graph of the predator prey population relations:
As the number of prey increases the number of predators can increase. An increased number of predators are able to kill more prey which reduces prey populations.

Eskimos is heavily dependent on animal protein (roughly 80%) (Harris, 1983; Weiss & Mann, 1990; Nelson & Jurmain, 1988) If this was also true of ice age hunter/ gatherers then human populations as well as herbivore populations, would have experienced massive starvation. Further, the more hunting techniques improved, in those final days, the worse the overall situation would have become. The famines resulting from prey extinctions, in a hunting economy, would make the local famines of today, or even the massive famine/plague cycle of the Middle Ages look mild.

This would have the effect of creating huge rifts in the social fabric of the times. In an economy based on hunting, there would have been a reduction in the quality of life which would have been extreme for everyone. It may have been accompanied by diseases that famine weakened people would have little stamina to resist.

The only places which hunting/gathering would have persisted, as the only economy, would be those environments which: 1) were not previously tied to the herd herbivores; the tropical forests and deserts; 2) still had large herds, e.g. the plains and the arctic.

The First Information Revolution

The perception of the world that the few survivors of the crash would have would be of a world of want, not the world of plenty which their ancestors experienced. They would have made a perceptual shift, from trust that the environment was one of plenty to the notion that it was a world of scarcity - a world without the resources necessary to sustain life. This might cause a change in their tactics, from reliance on *information* as a protection against hunger to tactics of accumulation of *real goods*.

The small pockets of people who survived would have had to find new economic bases. Because these were people who now expected and perceived a world of scarcity, the new resource base would have to be reliable, and controllable, and possibly storable against future want.

I suggest that people used their environmental knowledge, previously used for gathering, to begin planting and their knowledge from hunting to begin domesticating animals. This perception of scarcity provided the spur which made people give up a way of life, described as the last leisure society (Lee & Devore, 1979) and accept the difficulties, hard work, and reduction in quality of life which accompanies transition from hunting to early agriculture (Clark & Brandt, 1989).

Archeologists have found that the beautiful, fluted point technology of the ice age, which stretched throughout the entire new world, disappears at the end of the ice age. This indicates that there was a loss of skills. It is replaced by a meager technology of poorly made stone tools. These tools of the Archaic Age are different in different geographic areas indicating that any information network which may have existed in the Ice Age, was no more.

Those groups who could would have kept as much of their old life style as possible. They may have developed complex foraging strategies or strategies based on fishing (Suttles, 1960; Piddocke, 1965; Hazard in Harris 1983), or nomadic herding (Boserup, 1965; Cohen, 1977; Harris, 1983; Weissleder, 1978).

Regardless of the strategy developed, the perception would be, and would remain, a world in which people saw a need to accumulate goods in order to survive. It would be an economy based on "things" rather than on information. Things are different from information because it is not possible for me to give you an item and still have it as I can with information. This means that a world based on the perception of scarcity induces hoarding. The spirit of sharing, which exists among contemporary hunter/gatherers, was replaced by a spirit of competition.

This does not mean that a full fledged *laissez faire* economy developed. Group interdependence would still be necessary. People would base their new political and economic organization on the old. This suggests a communal group which has some notion of specialization and division of labor, a group where survival is based on accumulation of material goods and access to those goods is dependent on membership in the group. Group membership in contemporary early agricultural societies is based on kinship (Patterson & Gailey, 1987; Canerio, 1970; Cohen & Service, 1978; Service, 1962; Flannery, 1972)

The shift from hunting to farming makes more soft foods available, therefore children can be weaned earlier. This decreases the spaces between births which increases population (Brooks, 1991). With increasing population there emerges a need for better agricultural methods. The more mouths there are to feed the more it is necessary to plant, the more energy that is put into agriculture the more children are born. This is another instance of positive feedback (fig. 3).

In addition, children can do simple agricultural tasks at an early age but in hunting/gathering societies they need to learn far more before they completely pull their weight economically. This means that in an agricultural society children are an economic asset whereas

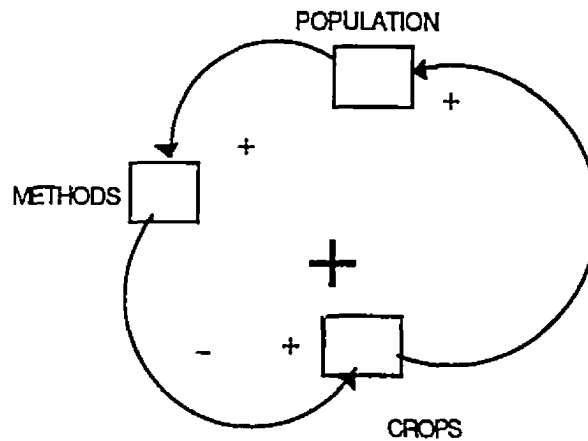

Figure 3: Agriculture and population, positive feedback loop: As there are more people more agricultural products are necessary, as there are more agricultural products children can be weaned earlier, as children are weaned earlier more children are born.

in a hunting/gathering society they are not. This contributes to growth in agricultural societies and control of populations in hunting/gathering societies.

In the hydraulic societies which became the first city states, political power was based on the engineering knowledge used to build irrigation projects (North, 1981). This knowledge was kept by the priest-kings and was the source of their power. In order to maintain power these early states invented the first information technology; writing (Ascher & Ascher, 1982; Canerio, 1970; Jones, G. & Kautz, 1981; Flannery, 1973; Lanning, 1967, Trigger, 1982; White, 1949; Cowgill, 1975; Wenke, 1984)

Writing was useful for recording the knowledge necessary to keep power. Writing can be seen as the first attempt to make information into a commodity which could be stored, passed from one to another and kept from those who were not members of the literate classes. This meant that in order to control certain information it was only necessary to restrict education.

This helped the established hierarchy create the perception of the state as the protector and source of wealth, knowledge and all things necessary for life - physical and psychological. Citizenship gave people the right to share in the wealth but did not give them rights to own the means of production. Participation in the power

structure was reserved to the ruling (knowledge owning) class by definition.

In these early city states the members of the elite had a paternal responsibility to the members of the group. The Bible story of Joseph's interpretation of the pharaoh's dream will serve as an illustration of how this relationship may have been perceived. The existence of the dream is an indication that the Pharaoh was expected to be privy to knowledge which others did not have. The dream told of seven years of plenty followed by seven years of famine. The actions of the Pharaoh in storing food from the years of plenty to be used in times of starvation shows that it was presumed to be the responsibility of the Pharaoh to insure that the people did not suffer. He could do this because he had superior knowledge and he had the power to allocate the use of wealth - the distribution of food. In contrast, it was not presumed to be a responsibility of western heads of state after the rise of capitalism to see to the feeding of the people in famines.

In addition, the acceptance of Joseph into the ruling elite based on his knowledge indicates that knowledge was seen as providing an entre to the ruling class. The story also shows how labor was determined by the elite: the children of Israel eventually became slaves in Egypt because of the group they belonged to, not because

of their activities or their skills.

Because security was no longer based on information shared by the all the people, but on the accumulation of material goods, it made sense for those who were stronger or more numerous to take goods from those who were weaker. Increased population also made the taking of land and labor - in the form of captive slaves - economically beneficial. This made physical security and military power a perceived need which allowed for an elaboration of the stratified state by creating another elite - the military - and further concentrated power in the hands of the elite who administered the whole (Schmookler, 1984).

The culmination of this world view was Rome.

Discussion

There are a few points in this whirlwind look at world history which I want to emphasize. The basic shift from the perception of the world as bountiful to a world of want preceded the invention of writing - the first information technology - and yet is dependent on it. This led to the perception that information was a source of power rather than something to be shared. This created a

condition where it made sense to make information into a commodity and to control it as if it were a thing.

The combination of these two perceptual shifts - from the world of plenty to the world of scarcity and from information as a thing to share to information as a source of power - created a world in which elites used the innovations of their culture to increase the wealth of the whole. Much of the wealth was distributed by the elites to be used by all who were considered members or citizens. But what we would consider the activities of ownership, the decisions about the use of wealth, were in the hands of the elites. Therefore, they benefited most from the production of wealth in the culture. The elites were able to live better, had access to education and the arts, and made the decisions about what would be developed and what would not. This last decision-making ability enabled the elites to direct the course of innovation and therefore the direction of development.

The hierarchical organizational structure of the early city states - where decision making power is limited to one person or a small elite - emerged from the relatively egalitarian organizational structure of the hunting/gathering band - where decision making power is shared by most of the members. This seeming "about face" becomes more understandable when we realize the

implications of the perceptual shifts which must have occurred. The story may have gone something like this:

In a world which has all of a sudden become perceived as poor, people would be willing to change some of their habits to work for a more stable resource base. Initially this did not involve a massive change in behavior. They only had to plant some seeds, remember where they were and then return for the harvest. It must have made sense to have some ordering of this activity. The shaman or grandmother, who would be the natural equivalent of a long term data base, may have directed the work and allocated goods. From this perspective the priest-king is an extension of this role, of one who allocates goods and labor for the good of the whole.

Over time increased reliance on crops instead of hunted and gathered foodstuff eroded the traditional egalitarian organization. This occurred because the scale of the organization changed as populations grew. All the members of an emerging city state were no longer known or related personally to the "chief" or ruler. This meant that the nature of the relationships changed from a loosely ordered organization based on common ownership and common information control, to a paternalistic hierarchy in which information is controlled and resources are allocated by

the central power structure (Gailey, 1987; White, 1949; Service, 1975).

A series of experiments, based on the work of Alexander Bavelas (1952; Leavitt, 1952), in organizational structure and task completion showed that for simple tasks, a hierarchical organizational structure, where all information is funneled through one individual who makes the final determination, is more efficient and less socially rewarding than a more heterarchical structure, where information is circulated through all participants. In experiments with more complex tasks, a more heterarchical structure is more efficient (Christie et al, 1952; Shaw, 1978). In follow up studies it was shown that in groups in which a hierarchical structure emerged the structure did not change (meaning the same leader continues to be the leader) regardless of the task. Groups which did not experience a hierarchical structure with one leader used different combinations of leadership by different individuals and groups for different tasks (Cohen & Bennis, 1962; Cohen et al, 1962; Shaw, 1978; Von Foerster, 1984).

These studies may provide an additional hint about how stratified states emerged from egalitarian hunter/gatherer bands. A hierarchy may initially have been preferred for the relatively simple tasks of planting and harvesting. More complex tasks would still be handled by

the more traditional organizational structure. As the activities related to agriculture took over more and more of the group's energy, the hierarchy would become more powerful and harder to dislodge.

With the elaboration of activities related to agriculture and an increase in population size there would also have been the necessity to handle the increased burden of how goods were distributed and how labor was recruited and used. As some groups became more successful it would be necessary to keep track of who belonged and who didn't. This would have created a variety stress.

Variety Issues

I suggest that the invention of symbolic representation (quipu, cuniform, heiroglyphics, and the many forms of iconic and alphabetic writing) relieved this variety stress and allowed for further growth in the size and complexity of the organization. An economist would attribute this growth to a reduction in the transaction costs.

A cybernetician would say that the invention of writing increased the variety of the ruling, knowledge owning class relative to other classes. That is, the ruling classes were able to gather, understand, use and

store more data and thus have more options than those classes which did not have writing. This increase in variety in the class responsible for administration and management allowed the size of the total system to grow until the varieties of the controller and the controlled were balance. This is based on Ashby's law of requisite variety (Conant, 1981) which states that the variety of a controller must match the variety of what is being controlled.

This rule or law is not interesting in considering one system which is in balance since it is just saying that one side of the balance equals the other side of the balance. It only becomes interesting when we begin to consider more than one system or to consider systems which are not in equilibrium.

The invention of writing may explain why some of the early city states grew more than others. The culture of the Moche in Northern Peru (Alva, 1988) was similar to the culture of the Incas except that the Incas invented a system of keeping records by using a series of knots on cords. The Inca were able to keep track of more taxpayers, record more transactions, and pay more soldiers than the Moche because each official's memory was enhanced by the use of knots; his variety was amplified (Ascher & Ascher, 1982).

According to North (1981) societies which were stable over long periods of time were characterized by a structure which did not permit the emergence of competitors from within and were sufficiently geographically isolated to make the cost of invasion too great for neighboring societies. Since the invention and use of writing or other information technology which increases the variety of the ruling class relative to other classes allows for a more effective hierarchy, it may be that this contributed to the development of monolithic structure.

We have said that the culmination of this form of organization was Rome. The fall of Rome can also be explained in variety terms as resulting from the increase in the variety of the population beyond the variety of the central authority to govern. As the empire grew geographically there were more people to be accounted for and to be taxed which led to complexity due to numerical growth. Population outstripped the ability of the taxcollectors and governors to administer. In addition, the empire became more and more diverse as it grew and citizenship was extended more and more easily. Thus, the empire eroded from within as well as being at risk from attack from outside.

This expansion made it necessary to defend a larger and larger border while policing a larger and larger

internal area. This meant that the empire relied more and more on military power. This made supporting the military more costly and fewer of the people were involved in maintaining it, all of which made for increased taxes and greater economic problems. It became less and less profitable to either be a member of the Roman empire or to administer it. Individual constituencies began to have more power and influence than the central administration. Thus it became more profitable to be more autonomous (North, 1981; Gunderson, 1976).

In summary, in economic terms the transaction costs began to outweigh the benefits. In terms of the experiments cited above, the task of administering the system became too complex for the hierarchical organizational structure, or more simply the system outgrew the limits of the organizational structure.

Transition

Just as the major instability at the end of the ice age created new problems which had to be solved with old knowledge and organizational forms, the fall of Rome left people with the problem of protection from military force (Miskimin, 1969; North, 1981). The political and economic forms continued to survive, each individual manor had the

same political and economic structure as the Roman villa. To solve the military problem the social pattern became a net of individual manors loosely allied for military protection. This organizational structure was similar to the alliances of a group of Germanic tribes each with its own chief or ruler providing military protection in exchange for fealty (North, 1981). This meant that organizationally the forms and structures of the Middle Ages came from a mix of both Roman and the barbarian forms.

The erosion of centralized political and economic authority contributed to a loss of learning because survival was based on a smaller economic unit - the manor - which could be administered without recourse to written records. Since alliances were loosely based on military support rather than on economic support it was not necessary for the political arm to be literate. Further, the chiefs of the Germanic tribes had not been literate so there was no tradition of literacy and political leadership. Those few who maintained the educational traditions of the Roman villa were in the minority and over time, through repeated warfare invasion and chaos, they were not able to maintain a literate tradition.

Thus, literacy - knowledge ownership and control - was left to the Church. Only the Church retained its centralized authority. The Church was a mixture of a

centralized bureaucracy and an austere religious institution (North, 1981). This mixture effectively severed the connection between knowledge and secular power. Those Church members who were interested in economic and political advancement did not need the protection and intervention of the secular power structure because they had the right of direct taxation through the institution of tithes. And the austere religious group maintained the tradition of learning while holding themselves aloof from the contamination of the political sphere. This broke the link between the control of information and the secular power structure. We will see later how very important this disassociation was to the economic development of the West.

The perceptual shift necessary for the second information revolution, like the first, preceded the invention of the information technology. Like the first perceptual shift it was the result of technological change related to survival and might be called an agricultural revolution.

The Agricultural Revolution

The economy of the early Middle Ages was based on agriculture. The serf, who actually tilled the land, was in a tenant-farmer relationship to the lord of the manor.

There were a number of prescribed responsibilities on both sides. Again, as in the hunter/gatherer economy, the population was in balance with the technological capacity of the land (Pierrenne, 1937). According to White (1986), the light, scratch plow could work land, which was considered sufficient for the support of one family. The basic assumption was subsistence farming - man was part of nature.

This perception, of one piece of land - one family, coupled with the technology, had the effect of keeping population under control. The balance of the number of people for the land's capacity could be maintained through economic control of marriage. If marriages could not take place unless there was a vacant tenement to farm, a balance could be maintained: in times when people died young, there would be early marriages and a high birth rate; in times when people lived long, marriages would be late and birth rates would be low (fig.4).

The combined technological improvements of the heavy plow, the hard horse collar, the use of horse shoes, and the open field system of cultivation constituted a technological revolution which changed the nature of the relationship with the land. For the first time, it was possible for one family to produce more than just what was necessary for survival. It allowed new soils, which had

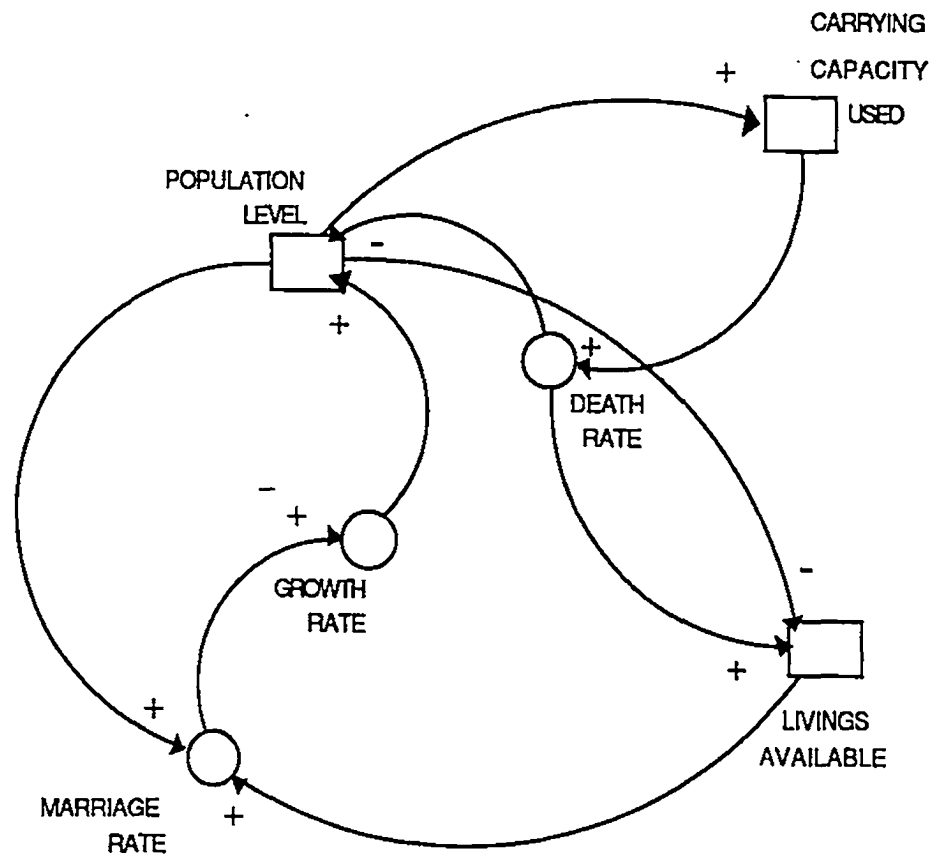

Figure 4: Population control in the manor economy: As the death rate increases more tenaments are vacated, as more tenaments are vacated more people can marry, as more people marry the birth rate increases, as the birth rate increases there are less tenaments available, as there are less tenaments available there are fewer marriages, as there are fewer marriages the birth rate falls.

been too heavy for the light plow, to be placed under cultivation. It changed the way people thought about the land and about their world. As White puts it:

...the standard of land distribution ceased to be the needs of a family and became the ability of an engine to till the soil. No more fundamental modification in a man's relation to his environment can be imagined: he ceased to be nature's child and became her exploiter. We who are descended from the peasants who first built such plows, inherit from them that aggressive attitude toward nature which is an essential element in modern culture. We feel free to use nature for our purposes because we feel abstracted from nature and its processes (1986, p.145).

This productive capability also had the effect of "unsticking" the old balance, by allowing young people to marry and colonize new land rather than making them wait for a vacant tenement to farm. Much of the colonizing was done on what had previously been waste land. Some of the towns which became associated with this land were free towns. Others were built and advertised by the aristocracy with new rights and privileges which would attract tenants (Pirenne, 1937). Because of the increase in production, it became possible to sell the excess for profit. Trade and money began to be more important to the economy (Pirenne, 1937; Braudel, 1986; Miskimin, 1969).

This period was one of growth and wealth, as more and more land was put under cultivation. By the twelfth century, the agricultural revolution was essentially complete (White, 1986). But populations continued to expand. It has been estimated that at the end of the twelfth century population was double that of the eleventh century (Miskimin, 1969; Russell, 1948).

Because the new agriculture was more efficient less people were needed in the agricultural sector. Since marriage controls did not exist any longer there was an excess of people. People who were not needed to till the soil became a new class of "masterless men", and presumably women, who were immortalized in the Robin Hood legend. They joined crusades or became mercenaries. Some of them started with a few goods and traded them for a profit and then bought more trading them at a profit as well. This informal trade was not regulated and formed the basis for some early trading fortunes (Pirenne, 1937). Those who were free of the control of the manor migrated to cities where they were free, in the words of the German proverb, "*Stadluft macht frei*" ("City air makes one free") (Pirenne, 1937). Or they founded their own towns and engaged in trade and specialized crafts.

Increasing urbanization, internal and external trade, the crusades, and a series of technological advances

on many fronts combine to give us a picture of great growth and economic expansion - positive feedback. Boom conditions existed.

This particular boom crashed when population exceeded the technological carrying capacity of the land to produce. This occurred in two ways: 1) there was no more new land to be put under cultivation; 2) the land already under cultivation became exhausted (Rostow, 1978). This resulted, in the fourteenth century, in a widespread series of famines, followed by the black death. This reduced the population of Europe by at least a third, and possibly by as much as a half. Population did not exceed pre-plague levels until the second agricultural revolution of the 18th century (Rostow, 1978; White, 1986; Miskimin, 1969; Pirenne, 1937; Gimpel, 1976; Reynolds, 1961; Russell, 1948).

It took three major waves of growth, famine and plague before the population stabilized. By then, new social controls of population based partially on the old system of tenement vacancy, and partially on the control of urban trades by guilds, had emerged (Schofield & Wrigley, 1986). An additional control of excess population was a permanent buffer class of under-employed people, who lived on the edge of starvation and felt the affects of shortages and local famines first (Rosenberg & Birdzell, 1986;

Braudel,1986). They were useful to fill the ranks of unskilled labor when harvests were good and the economy was prospering and they were the first to be disposed of when harvests were bad. This would not have been possible under a more paternalistic system in which goods were allocated according to social position rather than on the basis of participation in the economic realm.

After the reduction of population, people did not go back to the light plow, oxen, and the two field system. The social revolution was complete. Specialization, trade, increasing urbanization, increasing reliance on a money economy, and improved technology were all part of the society. They were taken for granted. New population growth was based on a new social order, with new social and economic mechanisms which acted as controls of population growth.

Although the economy was still primarily agricultural, there were both traditional landlord/tenant relationships and free holders. In addition, there was a specialized urban economy, and an expanding trade within Europe and with the East.

European society was diverse, that is, there were many different overlapping political and economic institutions each with its own set of accepted usages, understandings, organizational structure and its own sphere

of influence. Economically there were manor houses, towns which served free holding peasants, new towns, which had been incorporated by landlords to take advantage of the new agricultural economy (Miskimin, 1969), and there were cities and an expanding trade economy. Politically, there were a number of different organizational forms: feudal manors, town and guild organizations, and increasingly, a centralized government.

The Church was an economic, political, and social, as well as moral force. The belief in the perfectibility of the soul, in one lifetime, was central to the Christian faith. This attitude, and the mastery of nature gained from the new agriculture, supported the perception that people could change their circumstances. In addition, the Church of Rome, unlike the Church of Byzantium, supported work as a means of worship and technology as a means of good work (White, 1986).

All this diversity allowed an increase in social and economic fluidity. This was unlike Eastern hierarchical societies where all authority (political, religious and economic) were concentrated in the hands of a few.

Discussion

In terms of the law of requisite variety, the variety of European society, in the Middle Ages, was greater than any one authority could match. This means that no central authority could have controlled the system. Charlemagne tried to resurrect the Roman Empire but he did not have the administrative mechanisms to create an empire which could resist the instabilities from within (rivalry amongst his kin) or the invasions of Vikings, Magyars, Moslems (North, 1981).

The innovation of the plow and the changes which resulted could not have happened in a system with a single hierarchy which was allocating resources or controlling increases in technological knowledge. The new plow allowed new land to be opened up. This meant that serfs could leave their masters if the service was too oppressive. This created social dislocation and acted as a limit to power of the landlords and to the guilds. It created a more fluid society.

If there had been one authority it would have been in its interest to keep the plow controlled in order to maintain social control. The transaction costs of keeping track of the allocation of goods and labor, in a geographically mobile population, would have been too great

for a central authority. In other words the variety of a central authority could not have matched the increased variety of the population which resulted from the new technology. As it stood there was no central authority and it was not thought to be important to control all the people only those who directly owed service to the local lord.

In theory, every person owed service to someone in the hierarchy: the serf to the lord of the manor, the lord to the king, the king to god. In practice, the multitude of political forms - manor houses, guild run towns, free towns, towns which were newly set up through contract - left many administrative holes which allowed individuals to set up as independent peddlers and traders (Miskimin, 1969; Pirenne, 1937). Anyone who could get together the goods could trade. This established an economic precedent which encouraged initiative. Thus it decoupled the link between economic wealth and birth.

The benefits of the technology went to the user and the local authorities not to the central authority. The multitude of small competing groups within a larger social and economic structure meant that the course of development of new technology could benefit from competition. The individuals involved and the new political entities also benefited from a competitive system. For example, as new

towns opened up to serve the new farms, nobles advertised more beneficial villiage terms to attract serfs to work the new land (Pirenne, 1937).

Since the Church's authority was not tied to the political sphere and since the Church benefited from an increase in wealth of the citizenry in the form of tithes, it had no particular interest in maintaining social stability and every interest in encouraging innovation which might result in an increase in wealth (White, 1986). We see in paintings of the 14th century the virtue Temperance associated with new inventions: an hourglass in 1350, and later in the century with a complex mechanical clock (White, 1986). It made sense for the Western Church to stress good works which could be translated into charity in preference to stressing contemplation and mysticism as the Eastern Church did. It also had an interest in encouraging the various political entities in economic competition since, as the only religion, it would benefit from the increase in wealth of any one of them.

This is an important distinction since the Church was the only authority in the west which could have controlled access to information. The political powers of the time were based on military protection and military fealty (Miskimin, 1969; Postan, 1972; North 1981).

Because the Eastern Empire had remained more stable when Rome fell, the Eastern Church remained more closely tied to the political infrastructure. Because it had not suffered as greatly in the instability associated with the fall of Rome, it maintained contact with the rest of the world. As a consequence the Eastern Church was also more exposed to competition from other religions. Therefore it had an interest in maintaining the political and social stability of the Byzantine Empire for its own protection. It also made great sense for the Eastern Church to stress a mystical Christianity which helped people resign themselves to the burdens of oppression in the hopes of heavenly rewards.

Summary Discussion

At this point I want to emphasize the decoupling of traditional links between information and birth and between wealth and birth. The first decoupling was a consequence of the fall of Rome to barbarians. This meant that knowledge became the exclusive property of the Church rather than the property of the political ruling class. The ruling class did not see a value in literacy and the acquisition of knowledge. Any knowledge or benefit of literacy which the governing class wanted was, in modern

terms, "contracted out" to the Church. Thus we see clerics acting as scribes, letter writers and tutors but keeping control of knowledge. Power and position were inherited but knowledge was available to those who joined the Church.

The second was due to a combination of factors: the political and economic diversity of European society and the Church's monopoly on religion in the West. The Western Church had an interest in encouraging economic competition and economic innovation since it benefited from economic growth regardless of political status. This means that wealth generated by emerging urbanization, guilds, merchants, traders, and other innovators benefited the Church through the increase in tithes. Thus, the western Church had no interest in supporting the *status quo* since its organization as an economic and political entity was not based on maintaining secular stability.

I would also like to point out that in terms of the model of growth which was presented in the beginning of the chapter we see massive instabilities. These instabilities are important to developing new social, political and economic forms. This can be seen better when we consider those groups which did not experience instability. Hunter/gatherers who were not stressed by the massive extinctions did not feel it necessary to develop agriculture. The Eastern Empire did not fall to the barbarians and the links

between the Church and the political arm were preserved. Thus it was to the Eastern Church's advantage to support the *status quo* and resist innovation.

As we examine information technologies and the generation of wealth we will see how the instabilities affect the economic sphere and are important to innovation and to the generation of wealth.

Cybernetic notions of positive and negative feedback and requisite variety have also been introduced and will be important tools which will aid our perceptions of how wealth is generated.

To review the model of the process of growth presented in the beginning of the chapter:

- 1) There is an initial equilibrium condition, where needs are kept in balance with the technological capacity of the system to produce. This implies some form of control conscious or unconscious - a negative feedback loop which maintains the equilibrium.
- 2) The controls which maintain the balance or equilibrium are "unstuck" creating a positive feedback cycle.
- 3) The technological carrying capacity or system limit is exceeded resulting in a crash.
- 4) There is rebuilding of a new system on the basis of a combination of old and new forms.

In the succeeding chapters I will extend and modify this informal model in order to both understand and predict better.

Chapter II

THE PRINTING PRESS

Information Technology Overview

The second information revolution effectively started with the invention of the printing press and is continuing today. The printing press has had a greater affect on the way we think, and the way we do things, than any technology since the invention of agriculture. The press accelerated the breakdown of class ownership of knowledge. This set up a new political and economic dynamic. Where there was a free press, an educated merchant class developed and hierarchical control of the political arm was limited. Property rights were rationalized in favor of the private, and now educated merchant class. The result was the generation of wealth.

Where the press had been expelled or where it was in the service of the Church (the institution which traditionally had the right to control the ownership of knowledge), a literate merchant class did not emerge and

property rights were successfully used by the political hierarchy for their own enrichment.

Just as writing, the first information technology, changed variety relationships and made it possible for those who controlled the technology to increase their wealth and their control, the information technology of the second information revolution changed variety relationships in favor of those controlling it and as a consequence increased their wealth.

Introduction

I have said that a change in perceptions leads to change in social structures and that the difficulty is in seeing what those perceptions were before the new structures existed. Because of this I will try to show what people's perceptions were before the press and then try and point out the effects which the press had on people's perceptions of reality.

This chapter will deal with the way in which perceptions were changed. The next chapter will deal with the social and economic affects of this change in perceptions.

Equilibrium Conditions

Before the invention of the press and moveable type, all books had to be hand lettered, all maps and drawings had to be hand copied. This, of course, made books and other materials very expensive. Only the very wealthy could afford large libraries. Education often meant a lecturer reading aloud from a book while students wrote it down. The following story is offered as evidence of how expensive and rare books were:

As soon as Gutenberg and Schoeffer had finished the last sheet of their monumental Bible, the financier of the firm, John Fust, set out with a dozen copies or so to see for himself how he could best reap the harvest of his patient investments. And where did he turn first of all to convert his Bibles into money? He went to the biggest University town in Europe, to Paris, where ten thousand or more students were filling the Sorbonne and the colleges. And what did he, to his bitter discomfiture, find there? A well organized and powerful guild of the book-trade, the *Confrerie des Libraires, Relieurs, Enlumineurs, Ecrivains et Parcheminiers...* founded in 1401... Alarmed at the appearance of an outsider with such an unheard of treasure of books; when he was found to be selling one Bible after another, they soon shouted for the police, giving their expert opinion that such a store of valuable books could be in one man's possession only through the help of the devil himself and Fust had to run for his life or his first business trip would have ended in a nasty bonfire. (Goldschmidt, in Eisenstein, 1979, p.49)

In addition to the expense, there was what Eisenstein calls "scribal drift"(1979). An individual book

became whatever the scribe wrote. Over the years copies of the same work would differ markedly from each other because mistakes were copied and were the basis for new mistakes, and slight paraphrases were then paraphrased again and again. "Truth" was changed like in the children's game of telephone.

Today we consider books as authoritative; then, the existence of scribal drift probably led people to have more faith in the authority of the individual speaker rather than in what they learned from books, since it was not certain that the book was reliable. This is because the individual was a continuing entity which could be held accountable whereas the book was a disassociated item for which no one was accountable.

Knowledge was primarily an oral experience and was associated with things which could be observed as part of the speaker, like age or office. Just as people had the notion, before the agricultural revolution, that it was part of the natural order that a tenant's piece of land was just large enough to support a family, it must have seemed part of the natural order that those in authority knew things and others had to accept what was said. Both the Church and secular authorities supported this notion in the doctrine of divine right. The limitations of authority existed only in how one authority could limit the power of

others. For example, the nobles limited the authority of the king, the king limited the authority of the Church, the Church and the government were limited by the money they collected etc.

With few exceptions the class into which one was born determined the lifestyle one led. Economically, everything was tied, in one way or another, to nature. Most fortunes, including those of the nobility, were based on the land. Those who were making money through trade were still in the minority and they were dependent on the vagaries of tide and weather. People tended to have an attitude of fatalism and helplessness. There was little sense of social or economic mobility.

With a few exceptions, notably the great merchants of Italy, most merchants were of the artisan class; they sold or traded the things they made themselves. They made a subsistence living in a traditional manner. Most were illiterate and knew little about arithmetic. For some there was a growing awareness that learning of all kinds was a valuable skill. Sombart (1916) tells of a German merchant sending his son to Italy to learn division. This illustrates both the poor quality of the existing education and how far people were willing to go to obtain even a little mathematical knowledge.

Even among the great merchants business was a family affair, and there was no notion of business expenses and domestic expenses being separate. If there is no boundary between business and family, it is difficult for merchants to see business apart from themselves, as an object. This makes it difficult to analyze or change management and business practices because they are not distinguished from daily life. This makes the practices which are being used seem like part of the nature of things rather than things which can be changed and improved.

According to Marx (1970), production in pre-capitalist societies was a consequence of social relations. The laborer was not differentiated from the product of his labor; he was identified with the product. For example, the notion of an apprentice or a journeyman carries the implication that the person is bound to the person or household of the master craftsman or noble. In a tenant farmer relationship the person is identified with the parcel of land.

The printing press with moveable type began to change much of this.

Printers, Capital and Business

Printers were the first to experience shifts in their perceptions. Because they were the first to benefit from the increase in information availability and its ability to generate income, they became pioneers of new business structures and forms. Those which were successful were copied by other business people. In addition, one of the major markets which quickly developed was for books on business methods. Printers published those methods which they had invented and found successful. By looking at the print trade we can see the beginnings of what was to become capitalist economic structure.

In 1455, a mere five years after the appearance of the 42 line Bible, Fust and Schoeffer had already made changes in how the work was done and were running businesses based on standardized production (Febvre, 1984).

Printers were the first capitalists who could increase their income by keeping their equipment running. Other businesses which were capital intensive like trading or weaving were still tied to the vagaries and schedules of nature either in the form of tides and storms, or seasonally, e.g.- when the sheep were sheared. In addition, workers often divided their time between their work and some form of agricultural labor.

Printers were professionals; they only worked at printing. And, they were the first educated work force. Because of the intellectual demands of the work, printers had to be literate. They considered themselves to be intellectuals and gentlemen. They wore swords to show their difference from mere tradesmen (Eisenstein, 1979). Early journeymen in the print shops believed that they could become master printers and that there was social mobility. Master printers were accepted by the intellectuals in the upper classes. Thomas More's brother in law, John Rastell, was a printer who specialized in law. He was also a playwright, lexicographer, music printer and theater builder. One of Erasmus's closest friends, literary executor and heir was Boniface Amberbach, son of the founder of the Amberbach-Froben printing firm. Eisenstein (1979) suggests that the printer's circle in Basel which included Amberbach and Erasmus played an important role in the the development of legal studies of the early 16 century. Niccolo Machiavelli's father, Bernardo, indexed Livy's works for the Florentine printer N. Laurentii. The Estienne family of printers was intimate with the French royal household (Eisenstein, 1979; Febvre, 1984). Printing was a socially mobile trade.

Because printers worked with their hands, like laborers, and were intellectuals in touch with new ideas

they were in the forefront of movements for social change. Workers in the printing trade soon acquired the attitudes of modern workers. The strikes of journeymen printers in Lyons and Paris, 1539 and 1542, were modern strikes, called in response to owners' economies: cheaper food, taking on apprentices to do the work of journeymen and longer hours. The issues could have been taken from the news of today: real wages, non-union workers, working conditions, holidays (Febvre, 1984).

Unlike most artisans who plied their trades in the same place for generations, the first printers traveled from town to town setting up print shops, teaching the trade and moving on (Febvre, 1984). When they taught the rudiments of their trade they also taught their business methods. The precision demanded by the technical side of the work combined with the literate nature of what was being printed promoted an analytical attitude, that is, they thought about their work. Early print shops often were the intellectual centers of their time (Eisenstein, 1979). Because they were businessmen as well as technicians and intellectuals, they applied thought to business as well.

These things combined to give printers a new, rationalized approach toward production. Once they began

to realize there was a possibility that production could be improved it was simple for them to see ways to improve it.

Many of the organizational innovations of the printers became part of the modern capitalist economy. This occurred because interaction with the products of the press on a day-to-day basis showed people a new way of viewing their own capabilities; this in turn, changed people's view of the world and its possibilities.

Standard Type

Since books had been handwritten there were many ways to write each letter. The invention of the press with moveable type changed this and created a need for standard letters which would be easily produced and would be clear to read. Over time type faces evolved (Febvre, 1984; Eisenstein, 1979). The evolution of a few universally used type faces presented a picture of the world as standard and replicable. In addition, the standardization of letters combined with the increased availability of books made it simpler for people to learn to read. Printers had an edge in their thinking about standardization in the example of type - the first instance of standard replaceable parts.

Standard Editions

The first books published repeated the wisdom of the day. This means many books were no better than the old manuscripts. Soon however, a correcting feedback loop was established. Errors were corrected in each edition making new editions better than the last. This began to alter peoples' perception of the world. It created the perception that there was something to be gained in looking forward rather than just looking backward to the classics. It became a world in which people could interact with information in the form of the printed page and were not as dependent on interactions with people. And, that interaction did not change - in other words the printed word was reliable. This in turn made the world seem more reliable. Investigation could yield knowledge; it was no longer necessary to rely as much on authority for truth.

The feedback loop which resulted in corrected books in subsequent editions must have changed perceptions of how investigation and therefore science could proceed. The notion of replicability of results, in science, is remarkably similar to the observation that when editions ceased to change the true or correct editions had been achieved (fig. 5).

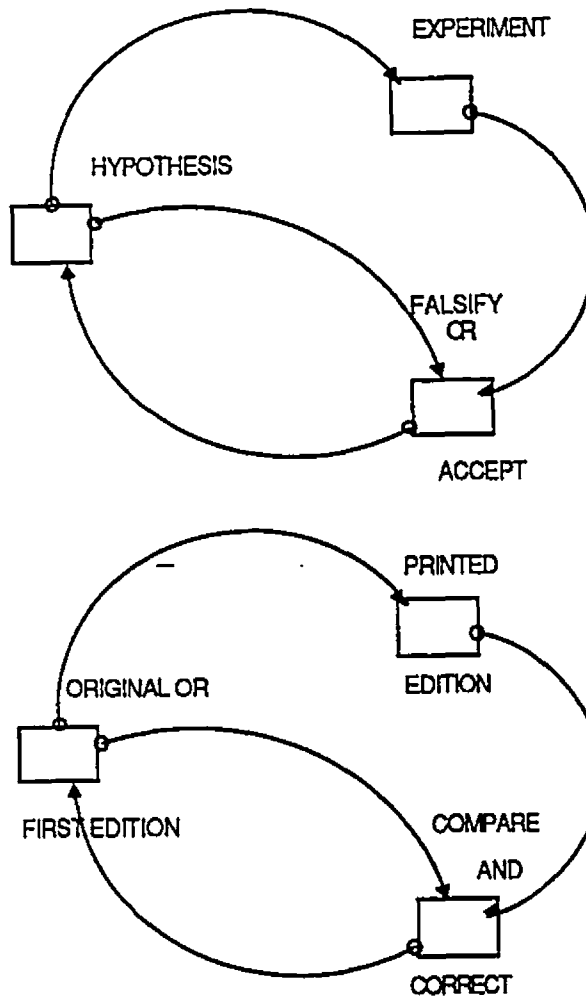

Figure 5: Correcting feedback in printed books: Each edition is compared with the "real" version. Corrections are made in each iteration. This could not happen where each edition was hand copied since new mistakes would invariably appear.

Francis Bacon was aware of the debt that the world of his day owed to the press:

We should note the force, effect, and consequences of inventions which are nowhere more conspicuous than in those three which were unknown to the ancients, namely, printing, gunpowder, and the compass. For these three have changed the appearance and state of the whole world.. (quoted in Eisenstein, 1979, p.3-4).

A community of scholars emerged. This community could be based on having read similar works and having an acquaintance with similar ideas. In the age of manuscripts, before printing, people were far more restricted in their reading material because of the expense and lack of availability. A scientific literature was established in the vernacular languages.

Braudel (1986) has noted that Copernicus may have done his original work alone, but soon after the publication of his results, in 1543, by Joannes Petrejus of Nueremberg, he posthumously became part of a scientific community. That community allowed communication between scientists that encouraged synergistic interaction and did a great deal for advancement in science and technology. This was a radical difference between the west and the orient and mid-east where scientists were more isolated.

Standardization of Language

Scholars in the age of manuscripts wrote and read in Latin. With the coming of the Renaissance there was also a resurgence of the study of Greek. The printing press initially published in Latin and Greek and was instrumental in raising the standards of and in formalization of those languages.

Over time there was more and more demand for works in the vernacular. In addition, the Protestant emphasis on the right of people to read the Bible created a market for translations into the vernacular.

Printers had a profound affect on the use and the standardization of language. Their use of a given form became accepted usage. There were printers who was directly interested in simplifying language and spelling. However, it was again through repeated usage, and correcting feedback that languages became fixed into the form which was seen in print (Febvre, 1984; Eisenstein, 1979).

It has generally been held that the Renaissance and the Age of Enlightenment are directly related to the rebirth of learning and the beginning of the reign of science. I believe that this is only partially true. The renewed interest in learning certainly did not hurt the

development of science and technology but the scholars of the Renaissance were classicists; they looked back to the golden ages of Greece and Rome. The press fostered looking forward to new and improved editions.

In addition, the classical scholars had a romantic conception of learning rather than the utilitarian concept which emerged with the rise of capitalism. Classic languages would be associated with science if the major cause of innovation were the ideas of the Renaissance. Instead, technical and scientific literature was associated with the vernacular fostered by the printing press.

Book Format

The first books, like manuscripts, did not have title pages, chapters or page numbers. They were bound as one continuous stream of information. Soon, however, books had title pages, then page numbers and finally chapters. This had become necessary because people were beginning to amass libraries, and the number of books a single person could own had dramatically increased with the reduction in expense. It was also necessary for the printers and booksellers to be able to tell one book from another easily. This evolution also indicates that the printing trade was becoming professionalized.

Title Page

The presence of the printer's name or mark on the title page was a form of advertising. It was also a mark of the ownership of publication rights, ideas, and authorship. The notion that ideas could be owned is a necessary pre-condition for a society which becomes wealthy through innovation. It indicates that new ideas and new innovations were a way of gaining respect and status in the society. This was not a small concern; Erasmus of Rotterdam had a great deal of trouble and worry over unauthorized editions of his work (Braudel, 1986; Febvre, 1984).

Finally, it indicated that books and ideas were becoming objects. This means that they stood apart from either the reader or the author. A title, like a name, indicates a separate existence. This allows ideas to be built upon and applied. It also fosters a more objective stance toward the world in general and therefore toward business and business practices.

Pagination and Chapters

Both pagination and chapters are signs of new organization. It indicates a further awareness of the book

as an object and also indicates that a book is something which is talked about in a community of scholars. Without page numbers it was difficult to refer to where an author stated a specific thought or to quote a passage and be understood. The spread of Arabic numerals as page numbers gave people a familiarity which pointed them toward becoming more "numerate".

Chapters indicate that people were becoming aware of how ideas cluster and could be divided and subdivided. It shows that the notion of organization was conscious; people were aware of the need to organize ideas for presentation and discussion.

Literacy

The printing press made it possible for more and more people to become literate. Before the press literacy was not seen as a necessary skill. Kings and nobles were often illiterate. The first spread of literacy was not among the upper classes who were already well off but among the rising merchant class. The first moves toward literacy may have been for business, but soon the merchant class began to value education for other reasons. Braudel talks about the new rich as being distinct from the old rich in

their patronage of the arts, their libraries and their value for scholarship (Braudel, 1986).

Literacy not only became more widespread but it became the test of adulthood. In contrast, those who were not literate became a lower class. This contributed to forming the perception that those groups within society who did not have access to education - women, servants, peasants - were non-adult.

By making literacy the test of manhood and participation in the society, it created childhood as a separate stage of life. Previously children were depicted as little adults, and because the culture was primarily oral rather than written children had access to everything adults said. The press changed this and thus invented both privacy and pornography (Postman, 1982). (The first pornographic book was published in Milan only 50 years after the introduction of the press (Berry & Poole, 1966; Eisenstein, 1979; Postman, 1982). The invention of privacy may be what is behind the traditional prudishness of the merchant class since prudishness was not a value of the Renaissance or of the scholars of the Enlightenment.

The notion of privacy was also influential in the evolution of the house in the late Middle Ages. Houses went from large common rooms to the evolution of separate

rooms for separate activities and for the rich, separate rooms for individuals (Chapelot & Fossier, 1985).

Perceptions and the Press

In the introduction we said that information could be defined as "a socially constructed word used to indicate portions of an environment, with which an individual interacts, so that they may interact with that, and other environments, in ways, which the individual defines, as better."

The press changed the environments of many individuals in the late Middle Ages so that they perceived the world in a new way, a less arbitrary, more standard, regular and replicable way. They applied these notions from their new experience of the world to other aspects of their lives. Out of this they created an entirely new epistemology, an epistemology in which the individuals were seen as actors who could create meaning for themselves rather than finding all the meaning in their lives from their participation and membership in a group.

Chapter III

THE PRESS AND THE RISE OF CAPITALISM

Introduction

One of the problems in historical research is that people tend to focus on the first instance of some new fact, technology, or idea. This is because historians take the first reference in documents or the first representation in art as evidence. The problem with this is that in order to understand the dynamics of cultural, social or economic change it would be better to know about the impact of these changes on large segments of the population. As one studying this dynamic I am less interested in the fact that Fra Luca Pacioli wrote *Summa de arithmetica, geometrica et proportionate* which included a section on double entry book-keeping which was published by Paganini in Venice in 1494 (Sombart, 1930; Eisenstein, 1979; Braudel, 1986; Miskimin, 1977), than I am, in how, when, and where those notions had their greatest impact on

the greatest number of people, and how that changed assumptions about business.

The reason *this* impact is important, rather than the first appearance, is that cultural change occurs in response to a broad number of people making individual choices on the basis of the evidence of their individual experience (Bloch, 1928; Harris, 1979). People experience the world through their technology. We saw in the first chapter how the plow resulted in a different *conceptual* reality for the tenant farmer because of the changed physical relationship between a man and the land he tilled. That could not have happened at the moment of the idea of the plow or even when the the first yields were harvested from land tilled by the new plow. It took repeated interactions before the boldest would take the step of marrying without a sharehold, moving to a new territory, or founding a new town.

In our own time, the invention of the internal combustion engine created no more than a luxury toy. It took Ford's manufacturing process to make this toy into a real vehicle, and it took time for people to experience the freedom of the car, for gas stations to replace blacksmiths, and for roads to be built, before the world began to base its transportation system on it. And it took even more inventions - the phone, the elevator, the

skyscraper - before the urban migration turned to a migration to the suburbs (Pool, 1977). But that's a story for later chapters. For now the important point is that it is through *interaction* with a technology that cultures, economies and organizations are changed, not because of the *invention* of the technology.

In this section I will trace the spread of printing in Europe and will show how the ideas associated with the press became concentrated in the Protestant countries.

The Spread of Printing

Compared to how slowly the plow made its way through Europe, taking almost three centuries before it reached the full extent of its usefulness, printing spread quickly. By the end of the century, a mere 50 years of print, the major urban centers had presses.

This rapid spread was facilitated by the great demand for books and the fact that the early printers were teachers as well as businessmen. They learned, and then traveled to places which did not have presses, and set up shop (Febvre, 1986). Gutenberg taught John Fust in return for the money he needed to develop the tools and equipment necessary for the development of the press and for the financing of the first edition. After the printing of the

famous 42 line Bible, Fust sued Gutenberg to recover his investment. He received Gutenberg's equipment in payment and set up his own press with Peter Schoeffer. Thus the development of the press received the spur of competition early.

Gutenberg took in pupils, and the records of the French Royal Mint in 1458 show this entry:

Charles VII the king ordered...(an) agent to go to Mainz to learn the art of printing which had recently been invented and brought to light there by Johann Gutenberg (Berry & Poole, 1966, p.14).

The authorities recognized the benefits of having printers in their countries. By 1500 the effects of the press were beginning to change the cultures of Europe. Before 1450 only Italy was experiencing a rebirth of learning, by the end of the century all the major cities of Europe were reading the new ideas of the Italian Renaissance and the old ideas of the late Middle Ages. Books in all the major languages of Europe were being produced. New trades of typefounder, compositor and type corrector were created. Traditional skills of metal workers, merchants and scholars were being used in new ways by the new technology (Eisenstein, 1979). Contrary to the fears of the Paris schoolmen, the press did not put them out of work, it gave them new roles as authors of texts,

editors and publishers. All the cities of Europe were experiencing the changes detailed in chapter 2, above.

The Reformation

In 1517 Martin Luther posted his 95 theses on the door of the Church at Wittenburg. Luther was not the first to criticize the church but he was the first to have a "mass media" at his disposal. His work was immediately taken up and published.

Between 1517 and 1520, Luther's thirty publications probably sold well over 300,000 copies... Lutheranism was from the first the child of the printed book, and through this vehicle Luther was able to make exact, standardized and ineradicable impressions on the mind of Europe. For the first time in history a great reading public judged the validity of revolutionary ideas through a mass-medium which used the vernacular languages together with the arts of the journalist and the cartoonist..(Dickens, in Eisenstein, 1979, p.303)

Luther wasn't the only one. John Calvin was aware of the power of the press before he was aware of his religious mission. He published a controversial commentary which disagreed with Erasmus' commentary on Seneca in 1532 with the hopes of creating a stir. He wasn't successful with this attempt. But he succeeded in creating a stir, after his religious conversion, with the first version of *Institutes of the Christian Religion* in 1535.

Calvin was the first of a new kind of theologian, made possible by the existence of the press, who had not taken orders or been ordained (Eisenstein, 1979). He was one of a number of thinkers, including Erasmus, who were able, because of the press, to make their mark without the blessings of the existing authorities.

The Reformation thinkers used the press to great advantage. And the press was benefited by the Reformation. All the religious reformers supported reading the Bible. Cromwell as well as Calvin and Luther taught that it was the duty of every head of household to teach his dependents and to read from the Bible. Reading became such a trademark of Protestantism that wealthy Protestants wished to be perceived as readers and increasingly portraits show them holding books or Bibles. Protestants were perceived as the people of the book (Eisenstein, 1979).

The Reformation spread rapidly because of the press, and the reaction was also swift. A Bull of Pope Leo X was published in 1520; it excommunicated Martin Luther, condemned his works individually and collectively, ordered existing works burnt and prohibited printing, sale, distribution and possession of any of his writings (Berry & Poole, 1966).

This established the initial distinction of the Protestants as supporters of a free press and the Catholic

Church as an institution which ruled on what books could be read and published. At first the controversy was good for the printing business. Printers published tracts, posters, and books written by both sides of the argument. The hotter the controversies raged the more there was to print. The Index of prohibited books also served as an advertising medium. As soon as a book or an author was on the Index the demand for his books increased (Fevbre, 1986; Eisenstein, 1979). In time, however, the policies of both the Church and the reformers became more restrictive. Both sides banned the works of the other.

If we look at the demographics of the Reformation we see that the Church had its greatest strength in the more populous countries of the South. As time went by and the positions of both sides crystallized it became more and more difficult for printers to continue their business in those countries. Protestant clerics were no more tolerant, but they were less powerful. This resulted in a migration of printers to the relatively more liberal Protestant lands of the north.

From 1517 on, major Catholic printing centers at Lyons and Paris in France, Venice, Rome, Milan in Italy and Seville and Alcala in Spain, lost ground (Eisenstein, 1979). Only the most powerful printers, who enjoyed the patronage of the Church and the royal houses, remained

openly operating. Finally, even Robert Estienne, of the powerful French printing dynasty, moved from Paris to Geneva (Febvre, 1986). The once thriving print business of Lyons became little more than a repackaging industry.

The rebellion of the Low countries against Spain serves as an illustration of how the religion of the country affected printing. When Antwerp fell to the Catholics in 1585 the once powerful printing firm of Plantain-Moretus found their opportunities contracting. One of the Plantain sons-in-law, Frans Raphelengius, went to Leiden as a Calvinist convert where there was a wealth of opportunity (Eisenstein, 1979). When the Calvinists were victorious in Holland, opportunities opened up for printers. They flocked there and a competitive printing industry resulted in what is now known as the Golden Age of Dutch printing.

Discussion

In thinking about the press and the Reformation I believe that the problem is seeing how it would be without the invention rather than how it was with the invention. If we imagine how things would have been without the invention we can begin to see the effect of the press.

If Luther had preached, and had not had access to print as an information channel, he would have been just another heretic. His Reformation would have been limited to a local disturbance. The circulation of his works, through the media of the press, meant that even had he wished to recant his ideas and works spread beyond the point of recall. By the time he was excommunicated the Church was already fighting a rearguard action.

Before the advent of the press, the pulpit was the only place from which to spread information. John Calvin would have had to have been a priest - in orders - to have access to an audience, and he would have then been under the rule of obedience.

In both of these cases, the presence of a literate laity and a free press was essential. Less obvious is the link with the agricultural revolution detailed in chapter 1 above.

The northern part of Europe was settled by "masterless men," like those of the Robin Hood legend. The heavy soils of Northern Europe were not suitable for agriculture using the light scratch plow of the mediterranean. But they were tillable using the new agricultural technology. This suggests that the Northern Europeans were the beneficiaries of the perceptual shift, which accompanied the agricultural revolution, that they

could control their own destiny. Thus, Calvin and Luther presenting a religion which stressed reading the Bible and forming one's own relationship with God was a logical continuation of the perception that individuals controlled their own destiny.

Before the Reformation, there were educated and liberal Catholics, and the Church was a supporter of education and innovation. There was no distinction between Bible reading and obedience to authority. They were not seen as mutually incompatible. The arguments of the Reformation made it seem as though reading the Bible and obedience were mutually exclusive activities. Both Catholics and Protestants became trapped by their arguments such that Bible reading became a greater feature than Luther intended and it became less a feature of Catholic worship. By the same mechanism, obedience to authority became a hallmark of Catholicism, and individual responsibility became a feature of Protestantism.

Business Structures and the Press

Granting for the moment that the press was intimately connected with the spread and strength of the Protestant Reformation, and granting that the Catholic Church took a more repressive stance after the advent of

the press than before, how does this affect the rise of capitalism?

Before the invention of the press, and before the Reformation, it was in the Church's interest to encourage learning, innovation and business development. This is because the Church had a monopoly on "civilized" (non-pagan) religion and had the right to tax individuals through tithing. The first merchant class developed in Italy, where there were more churchmen who could devote their time to teaching the wealthier laity. Because the Church was the only institution which controlled knowledge (see this work above/below), it had no fear that it would lose power through encouraging learning, and it had much to gain through the wealth of its members. Since the Church was not tied to the political powers, the growth of a strong merchant class in the cities was to the Church's advantage since it checked the power of the political sector. Therefore, it makes sense that the initial advances in trading, science and exploration were in the Italian city-states, Spain and Portugal, where the Church had its greatest strength.

In the first 50 years of printing the Church saw the press as an innovation which was to its benefit. The press was commended for its role in defeating the Turks (Steinberg, 1955; Febvre, 1939; Berry & Poole, 1966). In

Spain and Portugal, advances were made in mathematics, and there was a lively literature published in Christian mysticism. This indicates that the lack of advances after the Reformation, was not due to any *inherent* lack, in either Catholicism *per se*, or in the people of those countries, but was the result of the actions taken following the Reformation.

The success of Luther was partially due to the press. At the time of the publishing of the papal bull in 1520, thirty of his works had been published. The impossibility of silencing Luther must have given the Church a new perspective on publishing and on its position in the world. Certainly it seems that a Luther makes a Henry the VIII more likely; once a power has been defied successfully it is more likely it will be defied again, with less reason. This must have brought home to the Church the importance of cementing political relationships and of maintaining the *status quo*. Thus the Church supported those political structures which supported it - Spain, Portugal, Italy and France - and discouraged a free press.

These arguments may go part way in showing why, after the Reformation, it was in the Church's interest to maintain the *status quo*, and to discourage innovation, especially innovation which would tend to be socially

disruptive. It does not describe the Protestant link with the press, nor the link between the press and economic success.

Luther's initial success certainly helped make the Protestants supporters of the press and literacy, a relationship much like a TV advertiser supporting the spread of electricity. If the means to obtain the message aren't there the message won't get out. Luther, Calvin and the other reformers were dependent on the press for the spread of their message. Beyond that, it was part of the Protestant message that an individual attained heaven through his own faith and effort, not because of his relationship to an institution. This intensified and validated the experience of those who had already begun the conceptual shift from passivity to active participation in their own destiny, based on their experience of the agricultural revolution.

In other words, Protestantism appealed to those people who already had a self-reliant world view, and many of these were the merchants and traders, who benefited from the effects of the press - no control of learning, no link between the political, religious, and economic sectors of society (Hill, 1966). This means that there was a mutually supporting feedback loop in which Protestantism supported the press and literacy, literacy and the press enabled

individuals to be more innovative and reflective about how they earned their living, those who had the world view which validated self-reliance supported Protestantism, etc. (fig. 6).

Holland, the Press, and Capitalism

If I were to play devil's advocate, I would raise two objections: 1) Why were the Catholics and Jews of Holland just as successful as the Protestants? 2) Why do I insist on the effect of the press, why not skip directly from the support of Protestantism to the rise of Capitalism as Weber (1961) does? In answer to both, I will describe the dynamic which I believe took place. In order to do this I will lay out a number of observations and then attempt to tie them together.

Protestant Countries:

1) The press is not tied to the seasons and the weather, and because of the heavy capital investment in presses, type, etc. it is to the printers advantage to keep the press running as much as possible.

2) With the Inquisition and the subsequent control of the press many printers migrated to the various Protestant countries where they could make a better living.

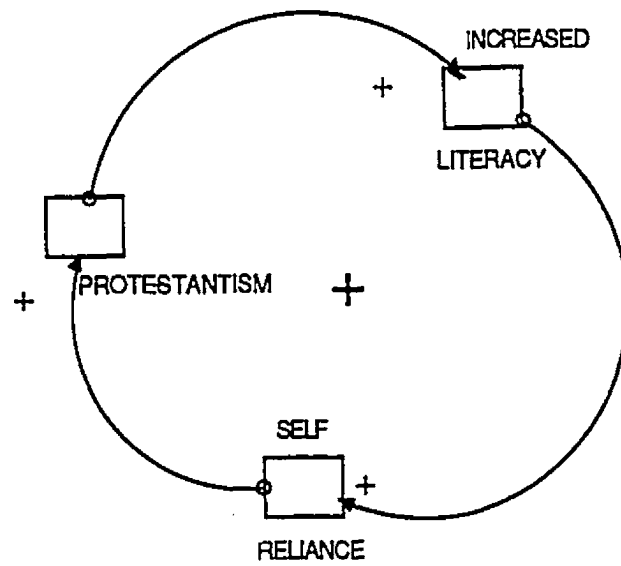

Figure 6: Relations: Protestantism, literacy and self-reliance: This is a mutually supporting feedback loop. Those who are most independent support literacy, literacy supports Protestantism, Protestantism supports literacy and self reliance.

3) The influx of printers in the Protestant countries created a competitive situation between them.

4) The combination of these factors resulted in publishing not only the books, bibles and tracts of the early years of the press but also posters, broadsides, maps, how-to books, business books, pornographic books, contracts, mathematical tables, charts, advertisements, histories, novels, etc. - in short, anything that would sell.

This resulted in a print conscious culture, a consumer conscious press and print as an ordinary means of communication.

Catholic Countries:

This is an important difference from the experience of people in Catholic countries. Febvre (1986) argues that control of the press did not have a profound impact on the Catholic countries, because there was a lively black market. Presses in Protestant countries easily supplied books to people who wanted them. The problem with this point of view is:

1) Reading, book buying, etc. was done only by those who were already literate, and was done in secret.

2) This did not encourage the spread of literacy, or the open use of books.

3) There would be few who would take even mild risks for ledgers, self-help books, children's stories, etc., which were common fare in Protestant countries.

This resulted in a condition where, to expand education to members of previously non-literate people, it was necessary to go to great lengths in Catholic countries, whereas in Protestant countries, posters, broadsides, and other popular media products, made literacy and the products which encouraged literacy were everywhere.

Thus, in answer to the questions above: 1) Why were the Catholics and Jews of Holland just as successful as the Protestants? 2) Why do I insist on the effect of the press, why not skip directly from the support of Protestantism to the rise of Capitalism as Weber (1961) does? I would suggest that the entire culture of the Protestant was print intensive in the same way our culture is television intensive. In the Catholic countries the entire culture was non-print intensive.

Simon Schama in his work on the golden age of Dutch culture (1987) asks a related question of what made the Dutch a "people" since they did not share religion, political affiliation, language, etc. He answers that there is a certain outlook or habit of mind which is

uniquely Dutch. These commonalties are intellectual attributes stemming from interaction with the products of a free, active and competitive press. I would suggest the Dutch were members of one of the first "media cultures"; cultures united by the common outlook which has been gained through interaction with information media.

Children, Women and Business

Neil Postman (1982) has identified one of the impacts of the press as the "invention of childhood". He observes that in a pre-press culture, children were not considered as a separate group. With the invention of the press adulthood became, and still is, defined by literacy or the completion of education. This changed the status of the non-literate to persons who were not accorded full citizenship and who needed protection. Schama notes that Dutch artists were the first to depict children as individuals rather than as small adults and to depict children's worlds of play, mischief and school (Schama, 1987).

Literacy being the test of adulthood acted in the same manner to place women in a separate protected class and to deprive them of the participation they previously enjoyed. Elise Boulding, in her history of women, *The*

Underside of History (1976), notes that women were relatively worse off after 1450 than before, although she does not attribute this to the press.

I believe that this deterioration of women's status and opportunities is because the pool of educated men grew relative to the pool of educated women. This left educated women at a disadvantage in making a name for themselves and left non-educated women classified as children.

Among the lower classes, the test of adulthood in pre-press times was simply biological maturity. There were no special skills necessary to simply be an adult. Skills were learned through imitation and experience. Because the culture was largely oral anyone in the vicinity could hear and learn. This was true of both boy and girl children. There was no special education for the vast majority of people. This meant that women were able to take over when their men folk were dead or incapacitated, because they had participated, as helpers, first as children and then as wives. Women ran every kind of enterprise from brewing to house building and textile manufacture. Widows trained apprentices, hired journeymen and carried on the family business (Boulding, 1976).

With literacy came the book keeping for artesian and small shop keepers, reading contracts in larger enterprises, and even reading the Bible and almanac in

agricultural work. Women, who remained largely illiterate, were not able to take over as they had been before. The nature of business changed due to the press and education but the education of women remained the same.

Before the press husbands and wives were more equally matched educationally than after the spread of print and education. This created the perception of women as intellectually inferior, even when social class was similar. Even when women were equally educated, the perception which was common in the mass of the culture hurt their opportunities. It became less socially acceptable for women to hire and fire or to continue to work at the family business after her husband's demise.

The perception referred to above of childhood as a separate from adulthood, also disadvantaged women with respect to participation in the mainstream of the economy. Women not only became identified as similarly helpless and in need of protection, but were now tied to their biological role in a new way as caretakers and protectors.

Related to these developments in a mutually causal relationship was the business as a separate entity. This is seen in the spatial differentiation of the business. In pre-press times, artisans worked in the common room. With increasing differentiation between home and work, business moved out of the common room, first to its own room, then

to its own floor - to a separate building (Braudel, 1986; Schama, 1987; Chapelot & Fossier, 1985). Women and children went from being part of the production process - to being subordinate helpers - to being separate and out of place, in the business context.

In addition, the wealth which was produced, for and by the emerging merchant classes, contributed to the deterioration of women's participation. Women's work became less necessary for economic survival. With new wealth came social mobility and social climbing. It became important for a family to aspire to the leisure class. One mark of the upper class family was that the women of the family did not work. This social statement became more important to the family's welfare than the financial contribution (Braudel, 1986; Schama, 1987).

Discussion

This apparent digression into the status of women and children leaves us with some interesting issues. Is it "better" to be a Dutch housewife with an expanding household to manage and children to spoil? Or to be the equal partner of a Spanish sheep herder, with a shorter, harder more poverty stricken life? Or was it better to have been the wife of a medieval artisan, helping to run

his business, without the benefit of reading or arithmetic and with the poverty and uncertainty of pre-press business? Generally, history answers that it is "better" to be a man in any of these situations.

These questions as to the relative status of women are beyond the scope of this work but I would suggest that the emergence of capitalism and the money economy has contributed to the definition of what is considered proper for economic history rather than anything intrinsic to the history of women *per se*.

In other words, one of the affects of the press was to create an economic system based on: 1) the objectification and separation of work from the home; 2) Increasing specialization, made possible because of increased educational opportunities; 3) rationalized property ownership; 4) use of rationalized mathematical business methods; 5) money economy; 6) contracts; 7) banking. All of these contributed to both the generation of massive wealth which made the quality of life better in terms of material goods, life expectancy, health, hygiene, leisure, education, arts, etc. for many and contributed to the relative disadvantage of women's participation in the economic, educational, political and religious realms.

Men became printers, scholars, merchants, and farmers and women became defined by their biology; the

distinction between men became objectified; men's social position became linked to what they did whereas the position of women remained socially defined by their birth as it had been for everyone in the pre-press era. Women became lumped together as non-men and that distinction defined them as non-participants.

The effect of the press on the status of children and the definition of childhood is generally not considered part of the economic history of the rise of capitalism. However, the more I thought about this the more I became convinced that this comment - that women and children are not part of the economic history of the rise of capitalism - is part of the effect I am trying to show.

Economics is the study of what contributes to the welfare of the group. Therefore, if I were writing about the economics of a pre-literate society I would write about the various subsistence strategies - hunting, gathering, horticulture, manufacture of clothing, houses etc.- and I would measure the success of one kind of strategy as contrasted to another by the success of one population compared with another. I would include data relating to the reproductive success of one group as compared with another. I would, therefore, include information about birth spacing, nursing practices, maternal death rates and child care as relating to the welfare of the group.

In more modern societies we use gross national product, balance of trade, unemployment, to stand as measures of success of one group compared with another group. However, we have largely forgotten that these are *measures* - proxies for group welfare they are not what *constitutes* group welfare. Group welfare still includes the demographic and reproductive variables regardless of whether or not they are counted.

The introduction of the press and the rise of capitalism allows economists to use symbolic, countable measures. This contributes to the invisibility of activities related to the welfare of the group which are not monetized. It is only now, with the increasing need for professional child and house care, that these variables are becoming visible, as they become monetized - part of the gross national product.

Thus, part of the success of rationalized business, in the early modern era, is based on the freedom of the business person to have the hygiene of life taken care of by women or serving people. This allowed the business person to take advantage of increased educational, and economic opportunities, which came with the press.

Chapter IV

THEORIES OF THE RISE OF CAPITALISM

Introduction

It is often proposed that the most important thing in the investigation of history or science is the collection of facts and observations. However, theories are even more important since theories are used to distinguish between observations and to guide the search for facts.

To illustrate this I will collect a set of facts, which are related to technology, perceptions, and Protestantism, and then will follow it with an absurd argument which will fit the facts as well.

Technological Interpretation

A map of the soils of Europe, shows that there are heavy podsoils where Protestantism flourished. The

southern countries, which remained Catholic are dominated by light soils.

It was suggested in the first chapter that the light plow was used in the light soils of the South, the heavy plow was used in the heavy soils of Northern Europe. Lynn White's (1986) explanation for a change in basic assumptions due to the agricultural revolution becomes important here. This is because people perceive the world according to their experience of it. If people have the experience that they are able to impact their own future through their actions then they are likely to believe that they can impact their salvation through their own actions and their own understanding. If, on the other hand, their experience tells them that they are not able to impact their future then they will be less likely to rely on their own interpretations in other spheres. Therefore, those people who grew up in a geographic area where it was assumed that man's relationship to the land was one of mastery would be more likely to believe salvation was in their own interpretation of the Bible (for a similar argument see Hill, 1966).

Politically, the fatalism of the South was reinforced by the established, traditional hierarchy based on birth, and on the Church. In contrast, the cities in Northern Europe were often new cities, founded by the

masterless men. They were often governed by a hodge-podge of special interest groups, the guilds, the king, the local gentry, or nobles, whose conflicting interests often, effectively, left the city ungoverned. In addition, the release of men from agriculture had enlarged many cities beyond their original boundaries; this often resulted in an area which wasn't under the jurisdiction of any authority (Pierrenne, 1937).

Correlation Interpretation

Taking the same data, and looking at correlations, disregarding technological impacts on ways of thinking, we come to other theories. One hypothesis might be that there is something in these soils which is particularly good for the development of Protestantism and capitalism. A soil test might show some nutrient lacking in the light soils of Southern Europe and present in the soil of New England. Add to that the fact that New England led the United States in its early industrialization just as England led Europe. This would lend support to the theses that soil types can predict industrialization.

The Weber Thesis

I suggest that this is similar to how Max Weber proceeded. He noticed that the Protestant countries were also the countries where capitalism started. He then went out and found statements of Calvin and Luther which supported his notion of the "spirit of capitalism". His thesis has been often refuted by citations from these same authors but because of the correlation between the rise of capitalism and the predominance of Protestants in the same geographical area, and because there has not been a satisfying explanation of why this correlation exists, his thesis has been remarkably hard to either prove or disprove (Landis, 1966). Most of the refutations have been limited to marshalling quotations from Protestant authors which do not support Weber's definition of the "spirit of capitalism".

I want to review the theories surrounding the development of capitalism inserting the effects of the press where I think they fit. I believe that this manner of proceeding will give us an insight into the relationship between development and technology.

Double entry book-keeping

Werner Sombart noted that during the Middle Ages businesses tended to be part of the total occupation of the family. There was little difference between private and public concerns. This was even true of the great merchants, who recorded household and business expenses together. He noted that businesses which are recognized as capitalistic have a less personal organization. Capitalistic businesses draw a distinction between business and personal expenditure, and between business and personal relationships. There is a trend toward having the business and personal spheres have separate space even if the space is only a different room. Sombart attributes this difference in attitude to the invention of double entry book-keeping. He quotes Pacioli's chapter 12:

You must enclose all journal entries - including written remarks - with a line if they are transferred. The same must be done in the case of memorandum entries. If you transfer (an entry) from the memorandum into the journal, you will cross out the (entry) by a single diagonal line. This will signify that the entry has been transferred into the journal...You may use all sorts of signs; it is best, however, to use common ones generally used by other native merchants. Then you will not appear to deviate from ordinary commercial practice. (Sombart, 1916 in Lane & Riemersma, 1953, p.38)

He cites this as evidence of emerging business autonomy. He believed that autonomy requires a notion of the separation of the business enterprise from the person of the entrepreneur, and that through the use of double entry book-keeping business becomes objective and mechanical. He says:

The conduct of a business herewith lost its highly personal character. A strictly businesslike procedure replaced personal management. The enterprise became autonomous and moved according to its own laws. This holds in a double sense: first, the enterprise emerged as an independent entity in the accounts, represented by its capital; secondly, this business entity now stood apart from the person of the entrepreneur, who, as it were, became his own creditor. (Sombart, 1916 in Lane & Riemersma, 1953, p.38)

Sombart dated the birth of capitalism as 1202, the year Leonardo of Pisa's (aka Fibonacci) *Liber abaci* appeared. He believed that the slow spread of scientific book-keeping was due to medieval traditionalism. He then notes how rapidly capitalism developed following the rapid spread of the method in the sixteenth century.

Pacioli's compilation of mathematical methods was published in 1494 by Paganini. He is considered the father of double entry book-keeping although he only compiled what was already known (Eisenstein, 1979). He was one of the many scholars who made use of the opportunity to spread his work through the press.

Because Sombart didn't take the press into consideration he had to fall back on traditionalism to explain why double entry book-keeping spread so slowly between the years of 1202 and 1450. He also has no explanation why Holland, England and the countries of the North were the most successful when both writers associated with double entry book-keeping were Italian.

It is also interesting to note that the person who is considered the father of double entry book keeping, Pacioli, is the one who wrote after the invention of the press, not the first to write about it, Fibonacci. This tends to indicate that the press was very influential in its spread.

New World Gold, Old World Riches

North and Thomas (1973) start their story of the rise of the West by noting that with the discovery of the New World, the focus of economic activity shifted from the Mediterranean to the Atlantic. This favored the countries which had Atlantic ports. These countries included both the Protestant countries of Britain and Holland and the Catholic countries of the Iberian Peninsula, Spain and Portugal.

The major question asked by North and Thomas is why the gold and silver which entered Europe through the Iberian Peninsula ended up enriching Holland, Britain and the other Protestant countries of the North. They believe that Britain and Holland established legal systems which rationalized land tenure. This, they claim, paved the way for establishing a notion of ownership of intellectual properties (copyright, patents, etc). This encouraged innovation and enterprise which led to economic development.

The Spanish throne needed money. There was more money to be gained from sheep herders than there was from farmers. This encouraged the throne to make laws which favored the *Mesta*, an organization of herders. This did not create rationalized land tenure and therefore did not encourage the development of ownership of intellectual properties. This made a society in which innovation was not rewarded and therefore enterprise did not develop (North & Thomas, 1973).

By the time the Spanish Throne was giving monopoly rights to the *Mesta* they had already acted against urbanization and trade through their actions in the Inquisition. This left agriculture and pastoralism as major, stable, income sources. The *Mesta* was organized and therefore both more visible than farmers and more of a

threat. Farmers were in a barter economy whereas the *Mesta* was engaged in cash trade. This was important since Spain was already experiencing a balance of payments problem.

The pre-Reformation impact of the press on Spain contributed to the discovery and colonization of the New World. During the age of incunabula the feedback loop which corrected the maps of the world had already started to work (fig. 7). Maps were still based on the Ptolemaic view of the world. Land masses and seas were shown on a flat disk without an organizing grid which gives perspective and scale to today's maps. But they had already begun to change. Even though the maps had the same appearance as scribal maps, this kind of evolution toward correction is completely absent before print (Eisenstein, 1979). In addition, tide tables and books on navigation were being published. These developments started the change of perceptions from a world which was largely unknown and unknowable to one which could be investigated.

Bullion, Wages and Prices

John Maynard Keynes attributed economic development to the perception of the possibility of future profit. He believed that the influx of New World bullion was responsible for the initial rise of capitalism (Keynes in

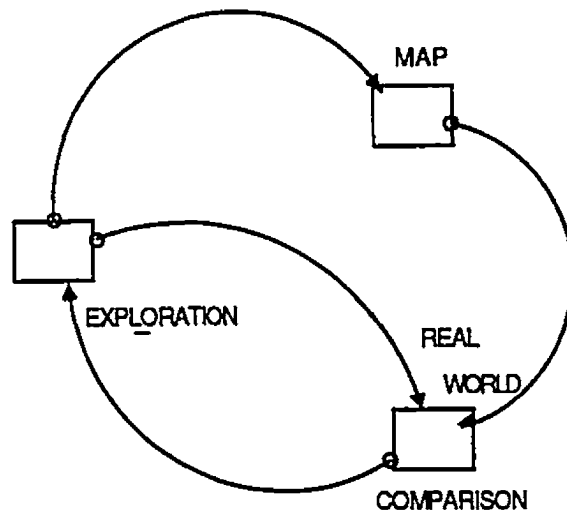

Figure 7: Dynamics of map correcting feedback.

Vilar, 1966). This leaves the problem which North and Thomas identified: why didn't capitalism start in Spain and Portugal rather than in Holland and England?

Hamilton (1926, in Vilar, 1966) also offered an explanation based on the relationship between wages and prices. He noticed that in Spain wages kept pace with prices whereas in Holland and England prices led wages. His argument stated that because there was a lag between prices and wages in the capitalist countries, business people were encouraged to invest.

This is identifying an effect and calling it a cause. Classical law of supply and demand states that the demand for goods and the demand for wages will eventually balance each other out since the market for goods is composed of the people who are earning the wages. This, however, is based on a closed system where the all the money and goods are circulating within one country.

Using Holland and Spain as examples of what happened generally in Protestant and Catholic countries can help illustrate the dynamic. The loop between prices and wages in Spain extended beyond national borders. In order to understand the economics better I believe it is necessary to look at the dynamics of wages and prices in an international rather than a national context.

Holland established itself as a manufacturing and trading center. Goods manufactured in Holland were sold in both national and international markets. Dutch merchants did not have to rely on local markets. This means that the demand for goods was greater than the demand for wages in Holland. The feedback loops which controlled the supply of goods, and therefore the price, were international rather than national.

Because Spain manufactured very little they were in competition with Holland's national market for goods. Spaniards had to offer more gold as an inducement for Dutch merchants to undertake the additional risk of selling abroad. Because of this and because of the great influx of gold, Spain became trapped in a ruinous inflationary spiral.

Spain's economy was an extractive economy rather than a productive economy like Holland's or England's. Extractive economies are those which use up finite resources without establishing a source of wealth (including both employment and goods) based on renewable resources. Spain extracted wealth from the New World but did not manufacture anything which could produce more wealth; even sheep herding became extractive since the sheep eventually overgrazed the land.

The relationship of a country to the international economy determines its wealth relative to the whole. Holland and England were producing wealth through manufacturing and trade. Because their markets were not confined to their countries, wages lagged behind prices. This may have further spurred investment but it was investment in existing enterprises. Gold alone does not create structure.

Structure is partially a matter of organization and standardization, and partially a matter of innovation and education. Printers left Spain during the Inquisition. This kept a merchant and capitalist class from developing because the activities related to trading and investment rely heavily on literacy.

Those who were already literate were also already rich. Therefore, gold and silver could not spur investment. In addition, those who wished to invest their gold found merchant enterprises in other countries which were profitable because business structures were already established.

Even those who realized that buying abroad was destroying the economy could not do much by buying at home. Local production did not have the efficiencies due to standardization and organization which were part of the

production processes of Holland and England. This meant that local goods were more expensive than imported goods.

Marx

According to Karl Marx (1970), economic progress in capitalistic societies occurs according to the following dynamic. Some form of improvement to a raw material is invented. In order to produce the improved product in quantity there is a need for specialization of laborers. The laborer exchanges his labor, as a commodity, for money in a free exchange. However, the work which is done on the material by the laborers adds surplus value which was not paid for in the exchange. This surplus value becomes profit, which is converted into capital which the investor turns back into the business in order to further increase investment and increase profit.

Because surplus value is added by the worker and because this is not paid for in the exchange which the laborer negotiated with the capitalist, Marx defines this as exploitation. In addition there is no doubt that there was considerable exploitation in the England of his day.

However, the explanation of wages and prices above allows us to look at Marx's arguments in a new light. If the lag between wages and prices in England and Holland was

due to the international nature of the market, then the exploitation, identified by Marx, was not *intrinsic* to the development of capitalism.

In addition, Spain was as exploitative as England. Spain had a semi-colonial relationship to an entire class of workers, the *Moriscos* (Vilar, 1966), but did not develop the necessary capitalist structures. Thus, exploitation alone is not sufficient to explain the rise of capitalism.

Marx also identified imperialism as stemming from the exploitative nature of capitalist economies and yet Spain did have colonies and did not develop capitalism.

The most valuable insights which come from Marx are that:

- 1) The ownership of the means of production allows for the accumulation of capital.
- 2) Technology can have the effect of increasing the efficiency of production and therefore profit. (I would suggest that organization and communication efficiencies be considered technology.)
- 3) In order for capitalistic notions of exchange of labor for money to develop, it was necessary for labor to be perceived as distinct from the laborer.

Marx notes that production in pre-capitalist societies was a consequence of social relations. The laborer was not differentiated from the product of his labor; he was identified with the product. For example, the notion of an apprentice or a serf carries with it the implication that the person is bound to the person or household of the master craftsman or noble. In a tenant farmer relationship the person is identified with the parcel of land (White, 1986; Sweezy, 1968)

All classes are involved in experiences which are shared with others in the same class. This creates class consciousness. The different perspectives of the different classes cause conflict. The playing out and resolution of the conflict is what advances society to the next level of development.

Discussion on Marx

These notions give us a picture of what is necessary for the development of capitalism, but not how it did develop. For Marx the notion of alienation, that labor as a commodity is distinct from the person of the laborer, is a necessary shift in perception.

In the development of printing as a capitalistic enterprise there are hints of this kind of distinction

between the laborer and the labor itself. Printers considered themselves to be gentlemen and scholars even though they worked with their hands (Eisenstein, 1979). This shows an awareness of the separation of the qualities of the work and the qualities of the person. The strike of printers in Lyons is evidence of the beginning of a notion of what constitutes a fair exchange for labor.

I will address this further in the discussion following this next section on property rights and innovation.

Property Rights and Innovation

North and Thomas (1973) have equated rationalized personal property and rationalized ownership of intellectual property. They believe that the rationalization of land ownership which occurred in England and Holland paved the way for the rationalization of intellectual property. They believe that this allowed innovation to flourish which led to the development of wealth. Their reasoning is that unless individuals are able to benefit from the result of their innovation they will not have sufficient incentive to innovate.

In *Structure and Change in Economic History*, North (1981) identifies two "Economic Revolutions" the first

from hunting and gathering to agriculture which paved the way for the creation of the state and the second in which political structures changed such that property rights encouraged economic expansion.

North properly identifies the early city states as granting use of wealth on the basis of membership and also properly assigns this as stemming from the structure of hunting/gathering societies.

Discussion on North and Thomas

I believe that North (1981) and North and Thomas (1973) make an excellent case but that these revolutions have been revolutions in information ownership rather than strictly revolutions in property ownership. These revolutions have been the result of a major shift in the way in which the people perceive the world.

I also believe that North and Thomas are identifying an effect rather than a cause. The perceptual shift combined with old forms used in new ways creates a new way of interacting with the world. This in turn sets up a new dynamic which further shifts perceptions.

Intellectual property is related to the notion of labor as a property since both involve the notion of production as a process rather than being limited to the

ownership of the object or owning an actual product. As Marx indicated it is related to the notion of alienation (labor as a commodity distinct from the person of the laborer) and as North and Thomas indicate it is a necessary perception shift in order for incentives for innovation to be established.

Above I presented evidence of the notion of the book as an object in the evolution of the title page, pagination, and chapters. This objectification of the book made it possible to separate the contents of the book from the book as an object. This made it possible to distinguish the producer of the book and the author of the book. In other words, the title page *created* the reality that owning the individual book did not give the reader the ownership of the ideas or the labor. That right was reserved to the author credited on the title page.

This would tend to indicate that the rationalized ownership of intellectual property, seen in the evolution of a title page crediting the author, work, *precede* both the notion of labor as a commodity and rationalized personal property *per se*. I am not claiming that the legal principle of ownership of intellectual property came first but that the *notions* of authorship, labor, and personal property are related and that through interaction with ideas presented in an objective form (a book as an object),

the notion of objectivity becomes part of the perceptions of people in the culture. Objectivity is a necessary precondition to separating notions of the person and his possessions or his actions. This separated the laborer from the product of that labor and set up the notions of ownership of intellectual property.

If Marx is correct in his idea that the notion of labor as a commodity depends on this separation, then the development of the book as an object is an important precondition to the development of capitalism.

The argument that was advanced by Sombart (above), is similar to that of Marx but from a different perspective. Sombart maintains that the use of double entry book keeping created a separation of the personal from the business perspective. This is the alienation of business from the person of the businessperson just as the notion of labor as a commodity is the alienation of labor from the person of the laborer.

As evidence of the importance of printing in this process of the emergence of the ownership of intellectual property I offer two teasing pieces of evidence: 1.) despite the fact that Columbus discovered the New World (and that this was known) the name that stuck was the name on the published (printed) maps; 2.) the person considered to be father of double entry book keeping is not Leonardo

of Pisa (aka Fibonacci) but Fra Luca Paccioli who compiled the version which went into print.

Schumpeter

Joseph A. Schumpeter, like Marx, believed in innovation as necessary for economic development. In his *Theory of Economic Development* (1983), he identified three economic themes. They are similar to the model presented in this work. The themes are:

1) The "circular flow of economic life as conditioned by circumstances" (Schumpeter, 1983) which is a general condition of equilibrium.

2) *Economic development* which has three major characteristics: a) It comes from within and is not attributable to outside forces. b) It is discontinuous rather than a smooth development. c) It brings about revolutions which displace old equilibria.

3) For Schumpeter progress occurs through the boom/bust fluctuations of the *business cycle*:

Entrepreneurs, financed by bank credit, make innovative investments embodying new technologies, resources discoveries, and so on. If these

innovative investments are successful, imitators follow...in the original industry and elsewhere and the economy embarks upon a dramatic upward surge: prosperity. Eventually innovations are completed and investment subsides; an avalanche of consumer goods pours onto the market with dampening effects on prices: rising costs and interest rates squeeze profit margins; and the economy contracts: recession. (Elliott, introduction of Schumpeter, 1983)

Discussion on Schumpeter

Schumpeter was describing what he saw as the working of the existing economy, he was not describing how capitalism came to develop. Because of this perspective he does not concern himself with why capitalism developed where and how it did. For me this is where Schumpeter's theory falls short. Surely there have been entrepreneurs in other societies. From the perspective of what was going on in the Middle Ages, China was more advanced technologically. This indicates that there were entrepreneurs, yet capitalism did not develop there.

In addition, Schumpeter did not explain why some downswings of the business cycle are more severe than others. He noted that innovations tend to come in clusters and that the extent of the clustering determined the intensity of the boom and the subsequent bust.

Here again, I believe that the invisibility of information technology is the problem and that surfacing information effects will help explain the problems. I will deal with the problems of the way in which Schumpeter sees the business cycle in subsequent sections and deal first with notions of innovation by contrasting the economic reward structure of China with that of the West.

China and the West

In China innovations tended to be isolated from the general culture. The Chinese were advanced technologically compared to the West and already had dynamite, windmills and the printing press. However, the social, political and economic context was very different from that of Europe (White, 1986; Rosenberg & Birdzell, 1986). By contrasting Europe and China, major differences in how inventions were received emerge. (Since the topic of this work is information technologies) Looking at the effect of the press as an example will help illustrate the differences in how inventions were received.

Currently the discussion of how the press was received in China and in the West revolves around the differences between the written and spoken languages of the East and West (Eisenstein, 1979). However, the various

scripts of Europe became simplified through correcting feedback over time (Febvre & Martin, 1986; Steinberg, 1955). This might have occurred in China as well if the feedback loops had been allowed to be established. This did not happen however and may have to do with how the political and economic structure was organized. I will review each of the arguments: linguistic and organizational.

Linguistic The invention of the press in China did not result in widespread literacy and the synergistic feedback which occurred in Europe. Western languages are based on a few phonetic characters which can be combined in an infinite variety of ways. Oriental languages are iconic; based on pictographs which are combined to make compound ideas rather than compound sounds. Therefore the number of characters is unwieldy - By the 12th century, there were over 8,000 known characters (Febvre & Martin, 1986). This made the use of type less of a saving for the Chinese than it was for the Western nations (Needham, 1956; 1969; Berry & Poole, 1966; Oswald, 1928).

Organizational The Confucian civil service hierarchy was well established by the time the press, dynamite, and windmills, were invented. This means that the way to economic and social advancement was controlled, prescribed, and tied to the political sector. As in the

hydraulic societies discussed above knowledge was owned and controlled by a single class. The economy did not, therefore, reward technological innovation and, in fact, like most established power structures tended to resist change in favor of stability. The most useful path to economic and social success was to gain the favorable notice of the Emperor and then to become part of the hierarchy. In order to insure continued family success, sons were educated in the conservative ways of the civil service. This meant that a new invention might be useful for gaining attention, but social change from the use of those inventions would have been unacceptable.

In addition, any new invention belonged to the Emperor or local lord. This meant that he controlled what was done with the invention. These factors may explain why so many of the inventions which proved to be agents of social change in the West kept the status of curiosities in the East. This may also explain why Chinese printing was limited to religious and governmental purposes and why it did not progress much beyond the wood block stage until its reintroduction from the West. (Although in 1403 the King of Korea commanded copper type to be struck to be used to spread laws and knowledge and so maintain peace and order, this did not spread to China (Berry & Poole, 1966).

In Europe knowledge was the domain of the Church but the Church did not provide a unified path to economic advancement which the Chinese civil service did. The Church was an institution which was separate from the political institutions. Its organization crossed political boundaries, had its own income and its own hierarchy.

European economies were not tied to a centralized hierarchy. Feudal political relationships were loose alliances for mutual defense which specified responsibilities for both participants: the king and noble or the serf and the lord.

The towns were more or less autonomous, governed by the guilds which made them free of feudal control. Townspeople tended to support the central government but expected the central government to reciprocate in some manner. As often happens where there is more than one authority, the rivalry between Church and state tended to draw off the energies of both participants and to leave the mass of common people less rather than more governed.

There was a growing tendency for merchants and traders to evade any form of control and to allow market mechanisms of supply and demand to dictate prices. This was a departure from older forms of control where prices were dictated by an authority which mandated a "just price". In addition, since new products, either invented

or imported, were not covered by any of the traditional forms, new products would be the most successful in terms of economic rationalization.

In short, there was no one authority which could control knowledge and hence innovation and change, and there were merchants and traders actively benefiting economically from innovation.

In addition, the experience of small incremental improvements which followed subsequent editions of the same work is similar to the notion of improving each invention or innovation which is how much of Western technology improved. This could not occur where the initial innovation was rewarded but then controlled. It needed a competitive environment in which small improvements would give an economic edge to the improver.

Autonomy, Experiment and Diversity

Rosenberg and Birdzell (1986) identify a combination of factors as contributing to the economic success of the West as based on three themes: autonomy, experiment and diversity. They state:

The key elements of the system were the wide diffusion of the authority and resources necessary to experiment; an absence of more than rudimentary political and religious restrictions on experiment; and incentives which combined ample rewards for success, defined as the widespread economic use of

the results of experiment, with a risk of severe penalties for failing to experiment (Rosenberg & Birdzell, 1986, p.33).

Their scheme is the most complete I have found as it combines both the context and the notion of experiment and innovation.

The problem with Rosenberg and Birdzell is that they do not try and explain why this combination arose where or how it did. They correctly identify that there have been other periods of economic expansion but note that expansion without innovation eventually encounters limits. They also correctly note that the line of causality does not always point in one direction. For example, innovation generates capital, which, when reinvested, creates further innovation.

They make an important point, in noting that, over time, Western societies gave their enterprises rights to make decisions, which other societies had reserved to the political or religious authorities. This creates a society in which economic enterprise becomes the effective mechanism for decision making. They state:

Virtually without thought or discussion, the West delegated to enterprises the making of a decision basic in the innovation process: which ideas should be tested and which should be allowed to die. For economic innovation requires not only an idea, but an experimental test of the idea in the laboratory, factory and market (emphasis added) (Rosenberg & Birdzell, 1986, p.22)

They correctly identify the role of competition showing that a competitive market rewards slight improvements in a product are economically. This sets up a correcting feedback loop which in optimizing for profit also creates improvements on basic ideas (fig. 8).

They note the importance of developing a social class which does not have a vested interest in preserving the *status quo*.

They outline their notion of a "growth system":

- 1) Emergence of an Autonomous Economic Sphere and a Merchant Class
- 2) Innovation by Extension of Trade and Discovery of New Resources.
- 3) Innovation by Lowering the Cost of Production.
- 4) Innovation by Introducing New Products.
- 5) Development of Sources of Innovative Ideas.
- 6) Uncertainty and Experiment
- 7) Overcoming Resistance to Innovation.
- 8) Innovation in Organization: Diversity.

Discussion on Rosenberg and Birdzell

Looking at this scheme in terms of information control may show why it developed where and how it did. The fall of Rome de-coupled the traditional link between political power and information control. This created a condition where the Church supported economic innovation in

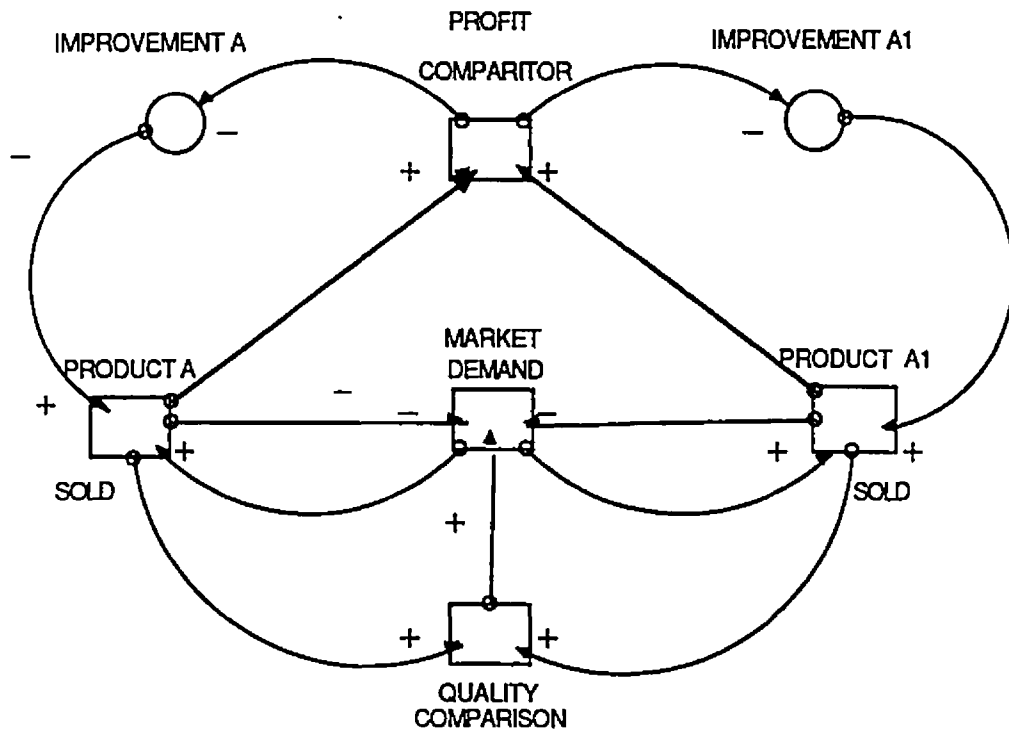

Figure 8: Competition optimizes production: As each competitor tries to capture the market the other is spurred on to improve the product.

order to increase its wealth. Thus, the only institution which could have controlled information elected not to do so. For example, monasteries were the amongst the earliest innovators in agriculture. They fulfilled a role in the economy of the Middle Ages much like the agricultural extension unit of our time.

The invention of the heavy plow, hard horse collar and three field system started a perceptual shift from fatalism and reliance on authority, to self reliance and the belief that a person could control his or her own destiny. These together with the greater efficiency of the new agriculture freed some people from agricultural labor to travel and trade.

These developments uncoupled the link between economic security and obedience to existing authorities. Guilds controlled the prices on traditional products, like bread. But as new products were invented, or imported, their pricing was outside the control of any of the existing guilds. This allowed market pricing to emerge.

The invention of the press spread the notions of future orientation, standardization, objectivity, and incremental improvement and change over time. In addition, it created an educated class who were not linked to the existing authorities. Information circulated amongst this class of people faster and more efficiently than the

authorities could control. This means that the press increased the variety of the people in the economic sphere faster than the variety of the ruling classes. This had the effect of further breaking down the reliance on authority. This resulted in the political and religious authorities being unable to control economic decision making.

Hierarchical control of the economic sector was poorly developed and rapidly broke down in competition with the emerging market system. This allowed the economic system to develop into a system which could handle more complex tasks, than a hierarchically controlled pricing system.

The task which the market accomplished is the selection of which items will be further developed and which will be dropped. It does this simply through the economic reward of popular (economically productive) products. Because the reward system is simple, and agnostic as to anything other than profit, it encouraged innovation in a multitude of areas: new products, new production methods, a variety of organizational structures and institutions, and it has discouraged the retention of those which were economically less efficient.

In Ashby's terms it has had the effect of encouraging the generation of massive variety which is then

"edited", "winnowed", or attenuated by the market such that the most economically successful survive.

In terms of the Bavelas organizational experiments cited in Chapter I, this is useful since then the best match of organization and task can be allowed to emerge; simpler tasks can be matched to a hierarchical organizational structure, more complex tasks can have a heterarchical structure; the structure of the assembly line and the research lab can be different if the structures are economically productive.

Summary Discussion

In this chapter I have suggested that the interpretation of economic history, based on the work of various economists and economic historians, is changed by taking the effects of the press into consideration.

The people of Europe were developing a new way of perceiving their world and their place in it. They were beginning to develop an epistemology based on individualism rather than on group, class, or religious membership. This is not to say that these institutions were unimportant, but their influence was limited to their respective spheres.

This is largely due to the relative freedom of the economy from institutional control. The economy was

influenced by these institutions but none of them could set prices, determine which products would be produced or what the course of innovation would be. In short, none of these institutions could control the economic sector.

This is a departure from the traditions of the Middle Ages where there was price fixing and much energy was spent on determining what the "just price" was (Miskimin, 1969, 1977; Postan 1972). Even today, in the economies of non-European countries, it is still a novelty.

Notions of variety and appropriate organization have been further explored. A position of technological determinism has been rejected since the press was invented in China yet there was no associated economic impact. In the chapter which follows I will further develop the notion of context and explore *how* these various changes in economic organization take place.

Chapter V

CYBERNETICS, INSTABILITY AND GROWTH

Introduction

We have now developed some *feel* for cultural change and some idea of economic development in relation to the press. We have thought about the dynamics of cultural change in relation to an informal model presented above in chapter one:

- 1) There is an initial equilibrium condition, where needs are kept in balance with the technological capacity of the system to produce. This implies some form of control - conscious or unconscious - which works as a negative feedback loop to maintain the equilibrium.

- 2) The controls which maintain the balance or equilibrium are "unstuck" creating a positive feedback cycle.

- 3) The technological carrying capacity or system limit is exceeded resulting in a crash.
- 4) There is rebuilding of a new system on the basis of a combination of old and new forms.

For this to be useful, we have to generalize the informal model and our impressions into a more specific theory or model which will allow us understand and predict cultural change and economic development in relation to information technologies.

A Note on the Structure of Presentation

Generally theories and models in cybernetics are "supposed to be" mathematical. This is because mathematics deals with the relationship between variables in their most abstract form. I have chosen to present my theory in the form of causal loop diagrams as visual representations of relationships combined with graphs which illustrate system behavior over time. I believe that this method of presentation combines the benefits of abstraction without the difficulty of mathematics. In addition it presents a

method whereby variables which cannot be quantified, on other than an ordinal scale, can be used in modeling.

Because this chapter is an abstract rendering of observations, the figures in this chapter carry most of the story. The discipline of confining the "story" in this chapter to the abstract presentation of relations has been difficult for me and is probably difficult for many readers. Because of this I have included examples as separate texts related to the presentation of relationships. Those examples which are too long to include have been placed in appendices. This chapter is a series of bits meant to be read in parallel - text, examples, causal loop diagrams and graphs.

Models and Modeling

This model, like any model, is a simplification. It is intended to focus attention on the dynamic aspects of the problem being modeled. This means that much richness is lost. Despite the loss in richness I think it is worth trying to create a formal model because it allows the relationships of the problem to become the focus instead of the things - the verbs rather than the nouns. For example, in the model below I talk about the relationship between information and innovation. I am trying to focus on the

relationship between them, not trying to determine what information is or what innovation is. I suggest that the reader take these notions as simplified general notions and view the model as a minimal explanation of general relations, meaning that minimally this is so in the general case rather than this is always so without exception.

Finally, it has been said that all models are false and some models are useful. With this in mind I will try to make this model useful by applying it to the affects of the printing press in Chapter VI, and to the electronic communications technologies - the telegraph and telephone in Chapter VII.

Approach

It will be useful to think about theory in parts: First, we will look at system behavior - the broad dynamics of economic or cultural change. This will give us a more specific notion of our informal model above and will tell us how the over all pattern of economic development should look in different settings - system behavior and how those settings relate to each other - super system behavior.

However, a problem with this perspective is that economies do not act. What is seen as the behavior of the economy is not due to actions taken by economies, but

rather actions taken by individuals, which results in a pattern, which can be called system, or economic, behavior. Therefore, I will then look at the micro-dynamics of the economy, or what individual members of cultures do, in their local settings, which results in the evolution of cultural change and economic development. This will help predict system behavior - what to look for in economies which are being impacted by current information technologies.

During this process, it is important to remember that the major impact of information technology is not the direct impact of a technology, like the impact of a new loom, or a new way of treating some raw material. The important effect is the impact of increased information access or increased information circulation has on a society or an economy. The various information technologies are the means whereby this occurs.

In the models which follow, a relationship is represented by the arrows between boxes which are variables. The way to read a diagram is to say an increase in the variable at the tail of the arrow causes a change in the box at the other (pointed) end of the arrow according to the indicated sign. If an arrow has a positive sign at the tip it should be read as: an increase on the variable on the tail of the arrow causes an increase in the variable

on the pointed end of the arrow - the variables covary. Conversely an arrow with a negative sign on the point should be read: an increase in the variable at the tail causes a decrease in the variable at the point - the variables vary inversely.

PART I - Super-System Behavior - Broad Dynamics

I suggest going back to "square one", to lay out assumptions and try to build a model of cultural change and economic development "from the ground up".

Assumptions

There are limits to the amount of growth possible given a certain level of technological development.

Most individuals tend to desire "more" of whatever they define as desirable within the perceived constraints of their situation.

In societies where there are elites they tend to have better initial access to all resources including information technology.

Model

Figure 9 indicates that growth occurs according to the amount of investment. This is a positive feedback relationship: as investment increases growth increases. this growth is ultimately limited by the growth potential for the current technology.

The form of this figure is a positive feedback loop inside a negative feedback loop. Tracing the loop around shows the following dynamics:

An increase in investment results in an increase in growth, which in turn increases investment

An increase in growth also results in a decrease in the amount of unused growth potential.

An increase in the amount of unused growth potential allows an increase in investment which leads to an increase in growth.

When the amount of unused growth potential is zero then investment stops, which stops growth. If the amount of unused growth potential goes down then there would be negative investment and negative growth

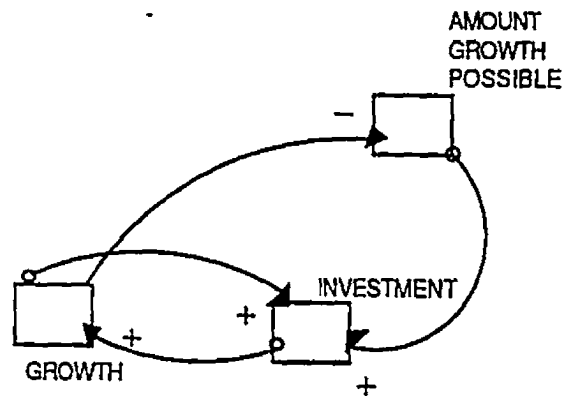

Figure 9: Classic control system: Growth and investment. This shows a positive feedback relation between growth and investment within a negative feedback loop.

This is a classic cybernetic system which has some reference point (the amount of unused growth potential) which controls the system.

Figure 10 presents a graph of system behavior over time. I suggest that the model is now a little growth machine. The graph of its behavior over time beginning at zero with some growth rate and some limit. At first the most important loop is the positive feedback loop - the system grows rapidly. As the limit is approached the affect of the negative loop becomes more important. Richardson (1990) has defined the shift in importance as a shift in loop dominance. In figure 10, the system behavior is influenced most by the positive loop from zero to point 'A.' From point 'A' to the end of the graph, the system behavior is dominated by the negative loop.

The shift in loop dominance occurs at the inflection point of the curve at point 'A'.

The curve just generated describes a smooth transition from positive to negative loop dominance as the system behavior goes from growth to equilibrium.

The shift in loop dominance in figure 10 is instantaneous. It assumes that the investors have perfect knowledge of when the limit of possible growth will be reached. In real systems investors can only guess when the

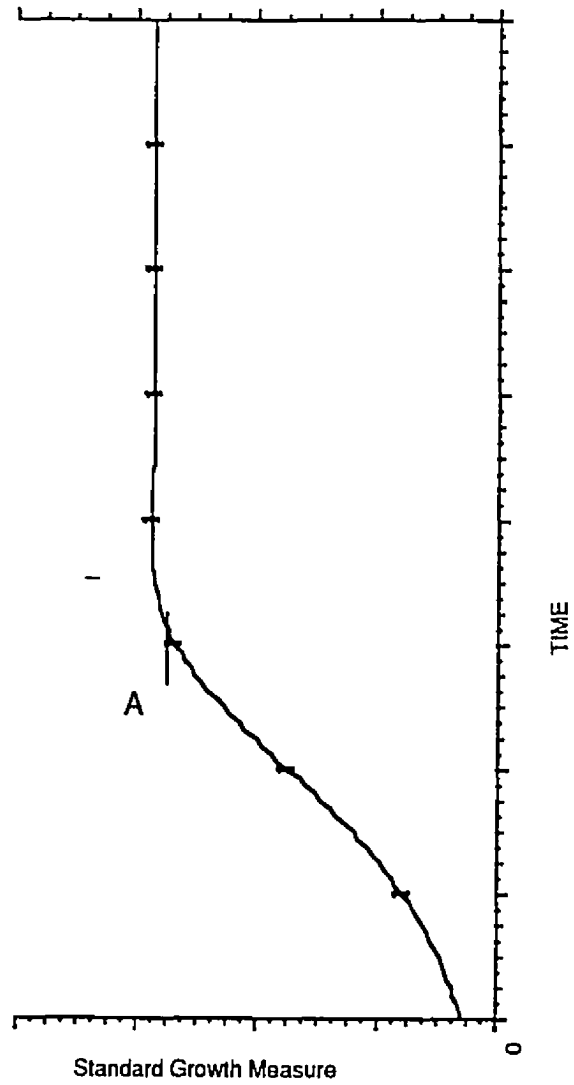

Figure 10: Graph of system behavior over time

limit of growth has been reached because they observe that each investment is subject to diminishing returns. This is seldom instantaneous.

Figure 11 shows several periods of growth. Investment is based on the perception of growth several periods ago.

Looking at system behavior over time shows the affect of this lag in perception. Figure 12 has the same growth rate and the same limit. It is the same system as figure 10, except it shows the effect of lags of two and three time periods. In each, the shift in loop dominance occurs at the inflection point of the curve at point 'A'. This suggests that what I have been calling instability in the informal model may be the effect of a lag in the shift in loop dominance.

Figure 13 adds innovation as a control of the amount of unused growth potential.

Innovation allows a change in the amount of unused growth potential. The controls keeping the system at equilibrium in the informal model are "unstuck" allowing positive feedback (Example 1). As the economy grows there is an increase in success - economic growth. As success increases there is a decrease in innovation: 1) each innovation is only able to produce a limited amount of growth - the law of diminishing returns; and 2) people

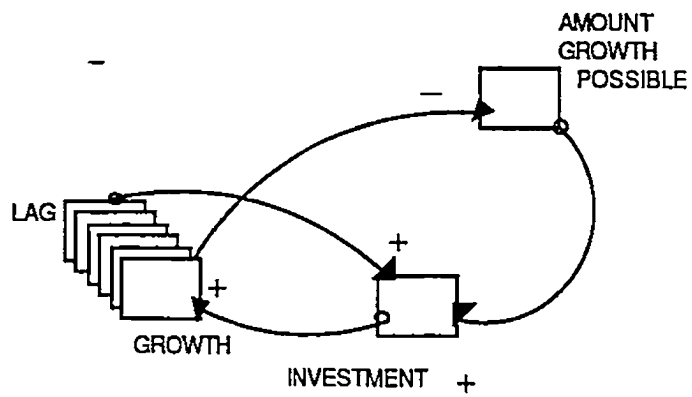

Figure 11: System with lag times included.

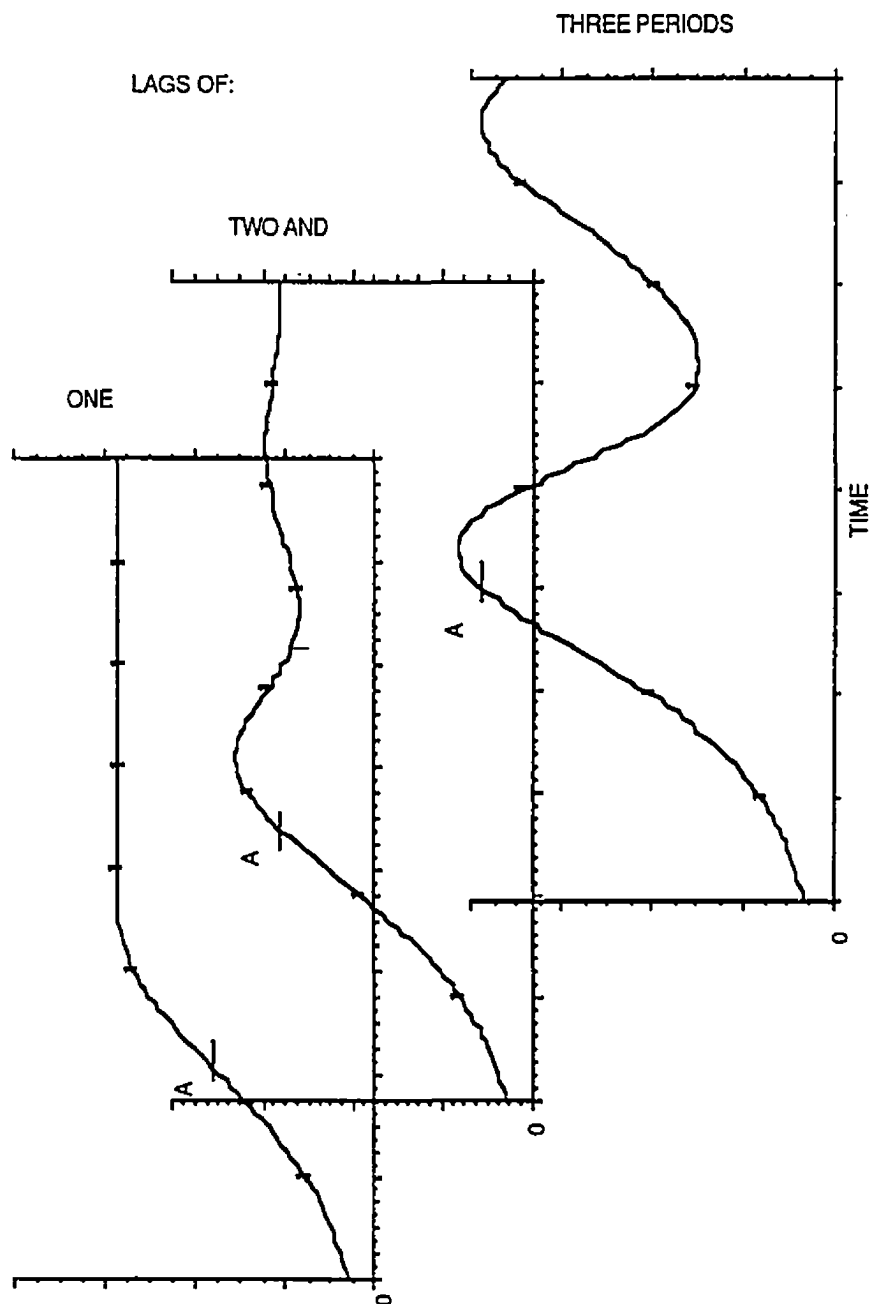

Figure 12: Graphs of the system behavior with lags of one, two, and three time periods.

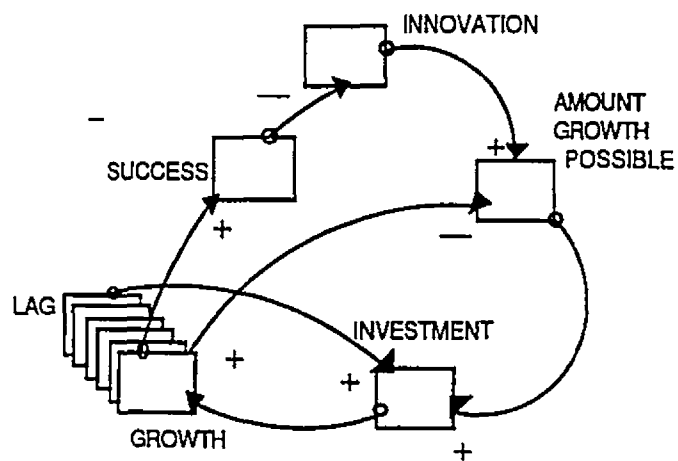

Figure 13: Innovation controls the amount of growth possible: As innovation increases the amount of growth possible increases, as the amount of growth possible increases the economy is able to grow.

(defined as standard "economic people") tend to continue to use successful strategies and technologies rather than search for new ones (we are defining innovation as totally new, not improvement of existing technology or strategies).

Example 1

The same land will feed more people under an agricultural system than under a hunter/gatherer system allowing populations to expand - more food allows more people, more people can work more land. The shift in the amount of growth possible is due to an innovation in subsistence technology.

Figure 14 shows the proposition of this work - information access increases innovation.

It is impossible to measure information and information access. However, if we imagine for a moment that it could be measured, information access would be some function of the amount known and the number of people who are able to know it. Thus, it is possible to think about and specify the relationship without the measure. I've added this to the model in figure 15.

In figure 15 information competent people are the members of a culture who are able to use the amount known. This is defined very differently in different cultures as indicated in example 2.

Example 2

In an early agricultural tribe it may be the people who are the members of a specific clan who have access to some type of information.

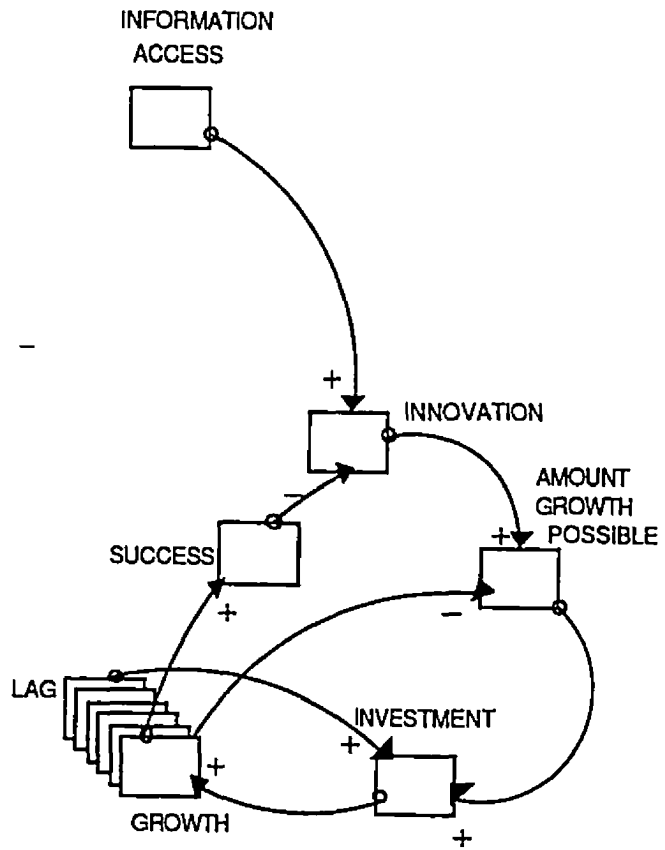

Figure 14: Information access controls innovation, and increase in information access increases innovation.

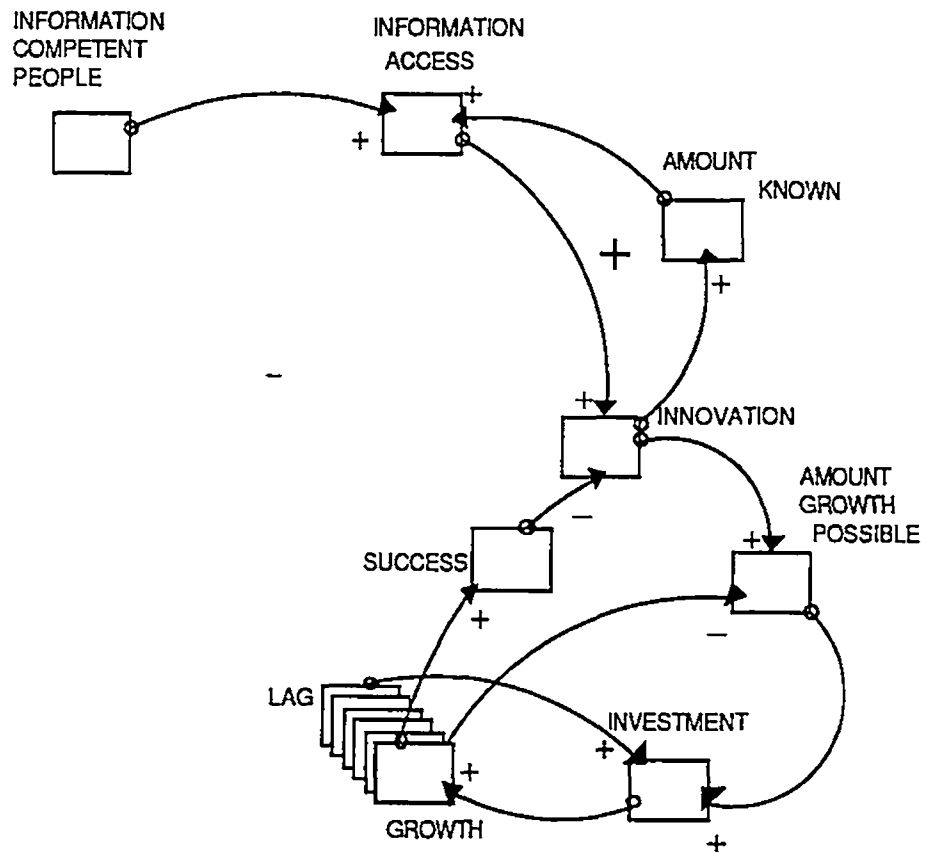

Figure 15: Information access: A function of the known and how many people know it.

In a post-literate society it may be the number of people who can read and buy books.

It may be the people who can afford to send telegrams or have telephones.

It may be the people who can use computers.

The link between innovation and the amount known, in figure 15, indicates that the amount known is increased by innovation regardless of the success of the result. This results in a positive feedback loop which is limited by success decreasing innovation.

The introduction of information technology is shown in figure 16. It completes another positive feedback loop.

The way this feedback loop functions is:

Information technology increases information access by bringing the amount known to more people.

This leads to more experiments and innovations.

This leads to an increase in the amount known. Finally, the increase in economic growth causes an increase in information technology.

The model at this point is a powerful growth machine only limited by the tendency of innovation to decrease over time (Example 3).

Example 3

There is a lag in this link depending on the technology. For the press the lag was long because of the time it

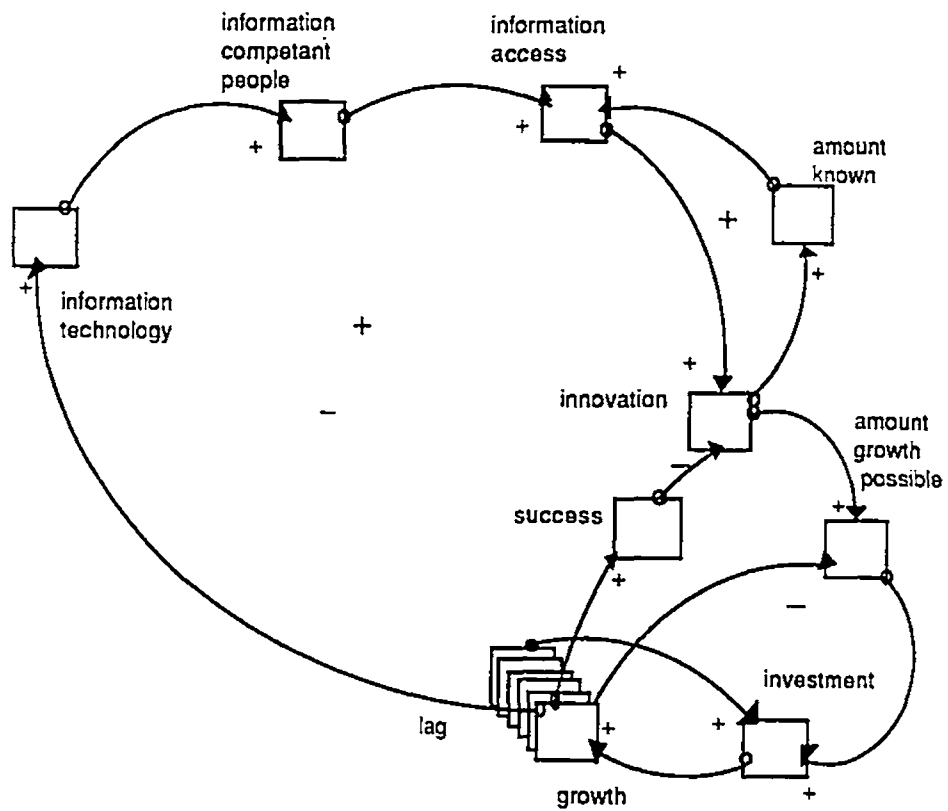

Figure 16: Information technology completes a positive feedback loop.

took for common people to become literate. For the telephone there was a short lag.

The timing of the initial impacts of information technology and standard technology are different. Standard technology impacts the sector of the economy to which it applies first, then other sectors are affected by the growth of the first sector. In contrast to this non-simultaneous impact, information technology impacts all sectors that have information access of an economy at the same time - the effect is simultaneous (Example 4).

Example 4

A new loom impacts the textile industry first, then the reduction in the cost of cloth allows for the manufacture of cheaper clothing, and this ultimately may impact the demand for detergent. (Non-simultaneous impact)

Telephones are introduced to the steel industry, banking and insurance, textiles, etc and savings in transactions costs are realized in every sector. (Simultaneous impact)

The elites of every country in Europe gain new access to information in the form of printed books. Absolutism of the centralized Renaissance State is based the increased ability of the ruling elites to administer more territory, track more taxes and wage better wars with paid standing armies due to an expanding bureaucracy (Trevor-Roper, 1967). (Simultaneous impact)

Figure 17a (non-simultaneous impact) illustrates the effect of taking the behavior of the system as illustrated in graph of system behavior - figure 12, above

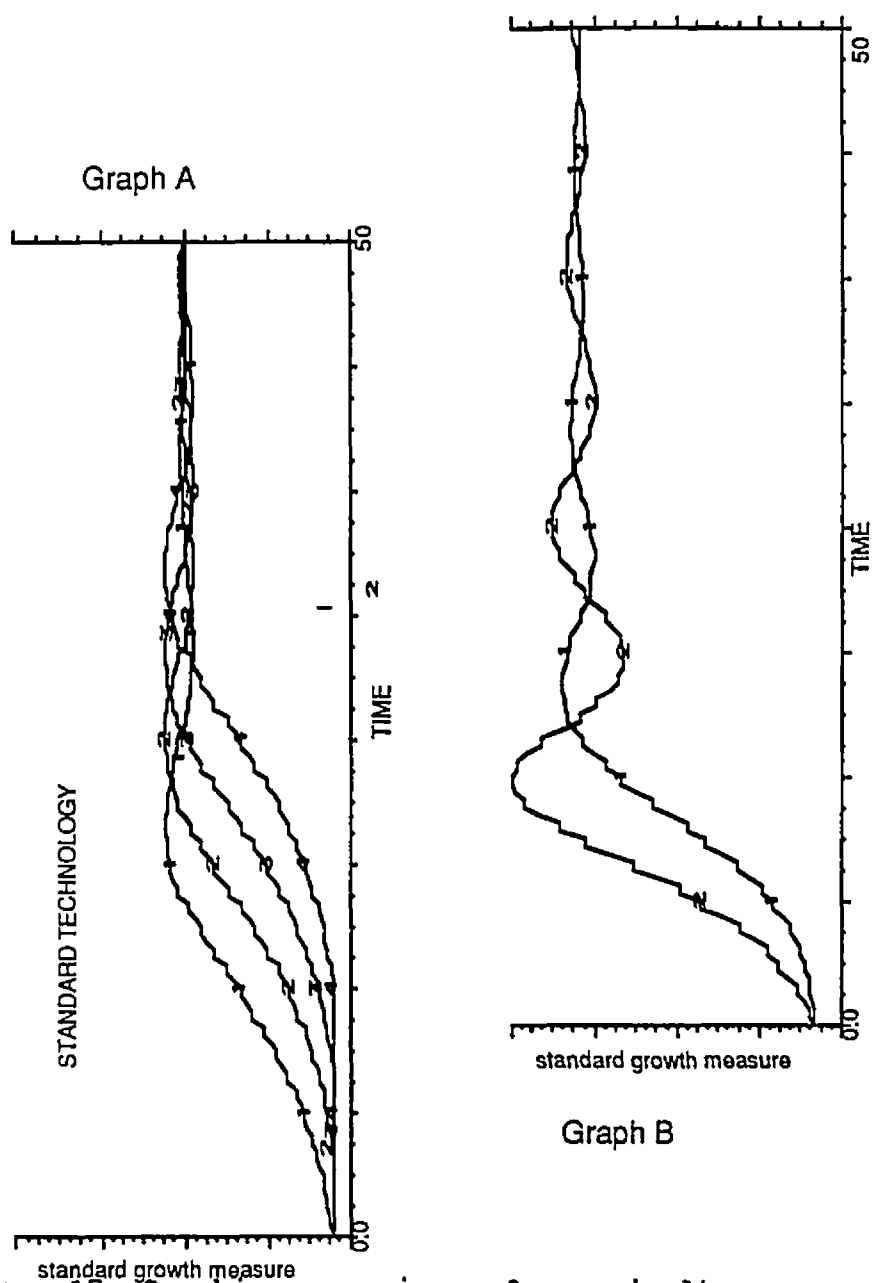

Figure 17: Graphic comparison of non-simultaneous and simultaneous impact of technology: Graph A shows smoothed non-simultaneous impact. Graph B shows steep simultaneous impact in curve 2 - information technology impact - smoothed non-simultaneous impact in curve 1 - standard technology impact.

with a lag of 2 time periods - and treating that as one of four sectors in the economy which are impacted by innovation and growth at different times. This has the effect of presenting a smooth transition from growth to stability. This is standard technology impact behavior. The second graph in figure 17b (simultaneous impact) shows a comparison of the impact of the four sectors being impacted by technology at different times (curve 1) and impact of summing them simultaneously (curve 2).

If the economy is behaving as it does in figure 17b1, there is a smooth transition from growth to equilibrium. When one sector is experiencing a shift in loop dominance from positive to negative, the rest of the economy is either in its growth phase, or it has attained equilibrium. This keeps the market for goods strong and the down turn in any one sector is not that bad. The shift in loop dominance is gradual and investors are able to perceive single sector adjustments appropriately.

If the economy is behaving as it does in the second graph of figure 17b2, there is a phase of remarkable growth when the slope of the growth curve is much steeper than it is in normal times because the entire system is dominated by the positive feedback loop. Individual investors observing this kind of ramped up growth are encouraged by what they see to invest more heavily, often going into

debt. When the shift in loop dominance occurs and the system shifts downward, investors tend to panic. They pull back which makes the downward shift more extreme. In addition, in the growth phase the market for goods is strong because all sectors are experiencing prosperity, but when the shift in loop dominance occurs there are no sectors which are growing, so the market for goods is bad. This can cause panic which accelerates the downward trend of the economy, causing an equilibrating contraction to turn into a positive feedback loop tending toward zero.

This is important because people act on their impression of a system. The notion that the perceptions of investors have real economic consequences, even if the perceptions are false, has been identified for individual companies by Soros (1988). In our model it acts to multiply the values of the loops. This means that when the system is dominated by the positive loop the Soros effect multiplies the growth rate. When the system is dominated by the negative loop and is experiencing a negative growth rate, the Soros affect multiplies that rate as well.

Figure 18 shows information technology increasing simultaneity, which increases the Soros affect, this leads to a multiplication of the growth (or contraction) rate. The Soros effect also tends to decreases innovation because

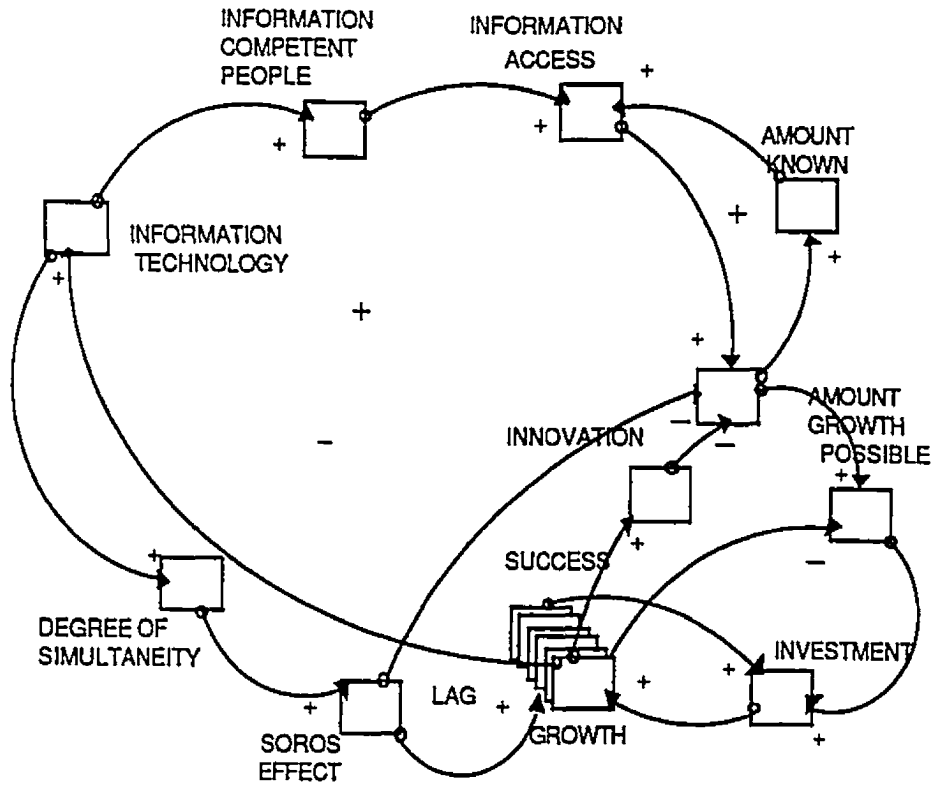

Figure 18: Simultaneousness and the Soros effect: Information technology impacts all sectors of the economy at the same time and people believe in that the growth will never end.

it intensifies existing trends rather than acting as a change agent.

Figure 19 illustrates a link between innovation and information technology which generates the differences in information technology impact in different contexts and countries.

Starting from the information technology box and tracing around the affect of this new link shows:

Information technology allows an increase in the number of people in touch with what is known, thus increasing information access. Some of the people who now have access to information innovate. Innovation creates economic growth and increases the amount known. Innovation also threatens the status quo by changing the membership of the elite and by new ideas, frameworks, technologies, religions etc. This threat causes the members of the power structure to act to decrease the threat to their status, by decreasing information technology and restricting information competency.

After the initial impact, the effect of simultaneity disappears leaving the model as pictured in figure 20. By changing the strength of the various links we can generate the behavior of the system in different contexts.

In figure 21 the link between innovation and perceived threat is strong. This causes the existing power structure to act to control information access by controlling information technology and restricting information competency.

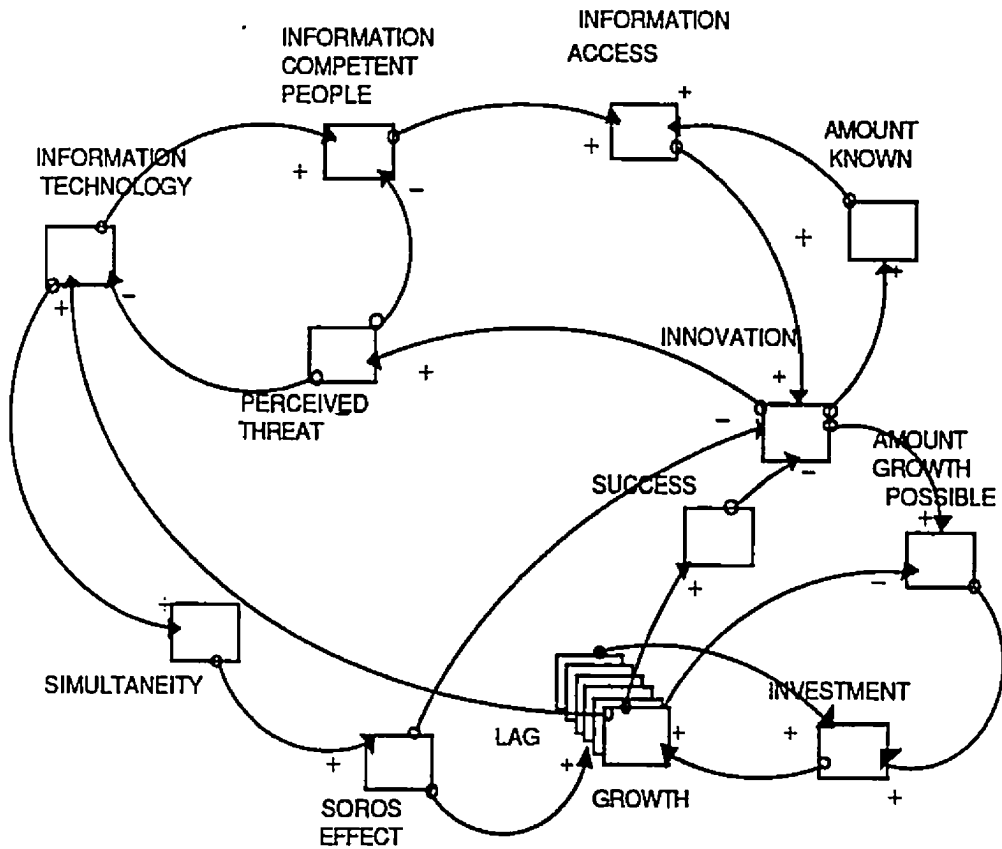

Figure 19: Perceived threat to the status quo: Innovation increases the sense of threat, the "powers that be" suppress information technology and people with high information access.

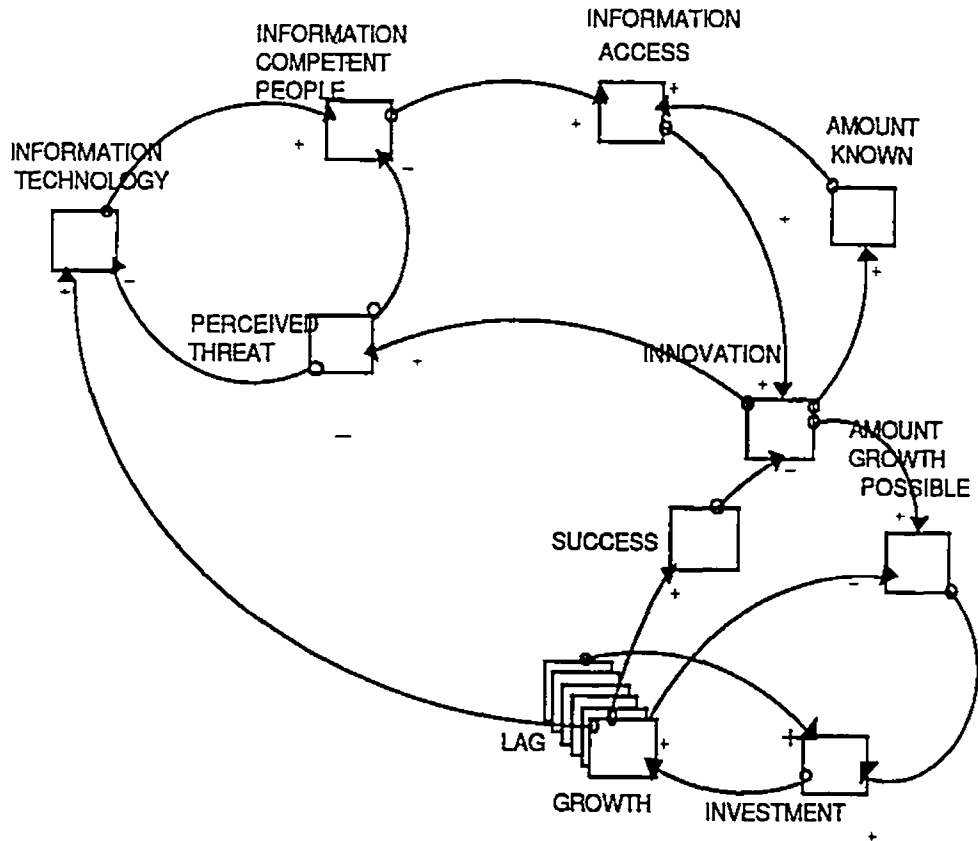

Figure 20: Relationships after the first phase: The Soros effect and the effect of simultaneousness disappear leaving the model as pictured.

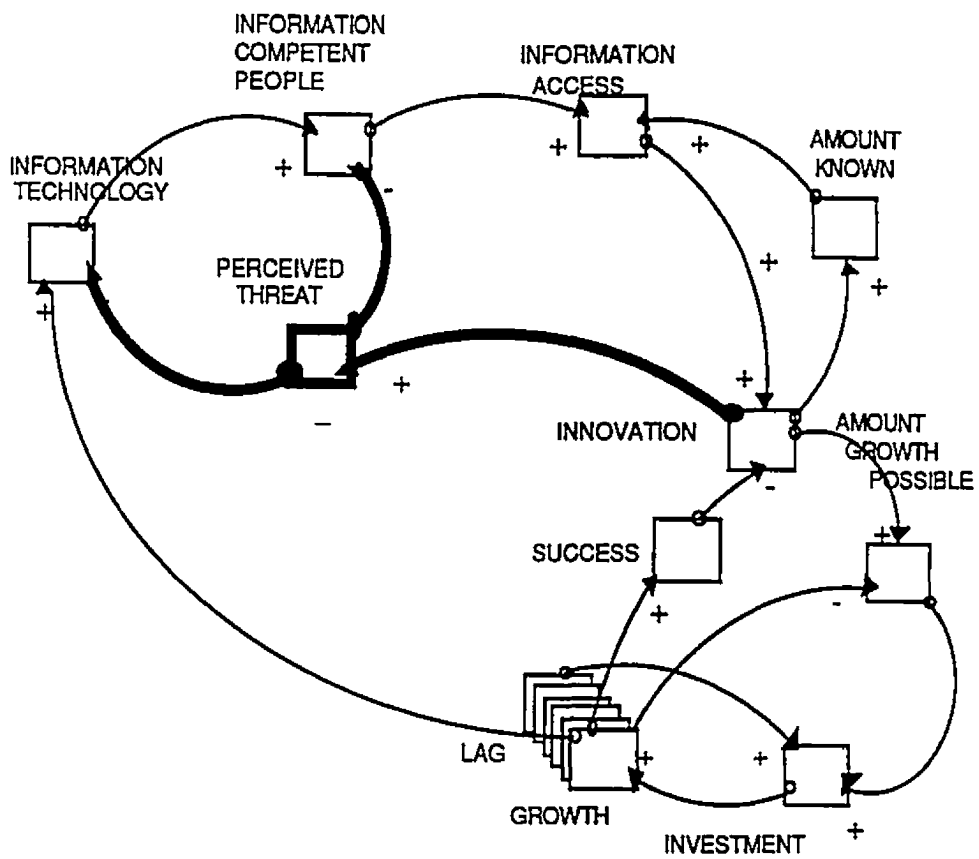

Figure 21: Strong threat: Members of the status quo act to suppress information and information access.

By tracing around we see that a decrease in the number of information competent people causes a decrease in information access. This decreases innovation, which decreases the amount of growth possible and decreases investment and growth.

In figure 22 the link between innovation and perceived threat is weak so the relationships remain the same and the system grows.

Implications and Conclusions

In all instances where there is an introduction of a new information technology, system behavior can be broken into two phases.

First phase behavior of the social and economic system is the same in all instances - simultaneous growth. This growth comes to an end when the amount of growth possible from the first round of innovation has been attained. Because of the effects of simultaneity and the Soros affect this growth will be extraordinary and the shift in loop dominance from positive to negative will be extreme, causing a depression or crisis.

I have assumed that the elites of the society have better access to information technology. Therefore, first

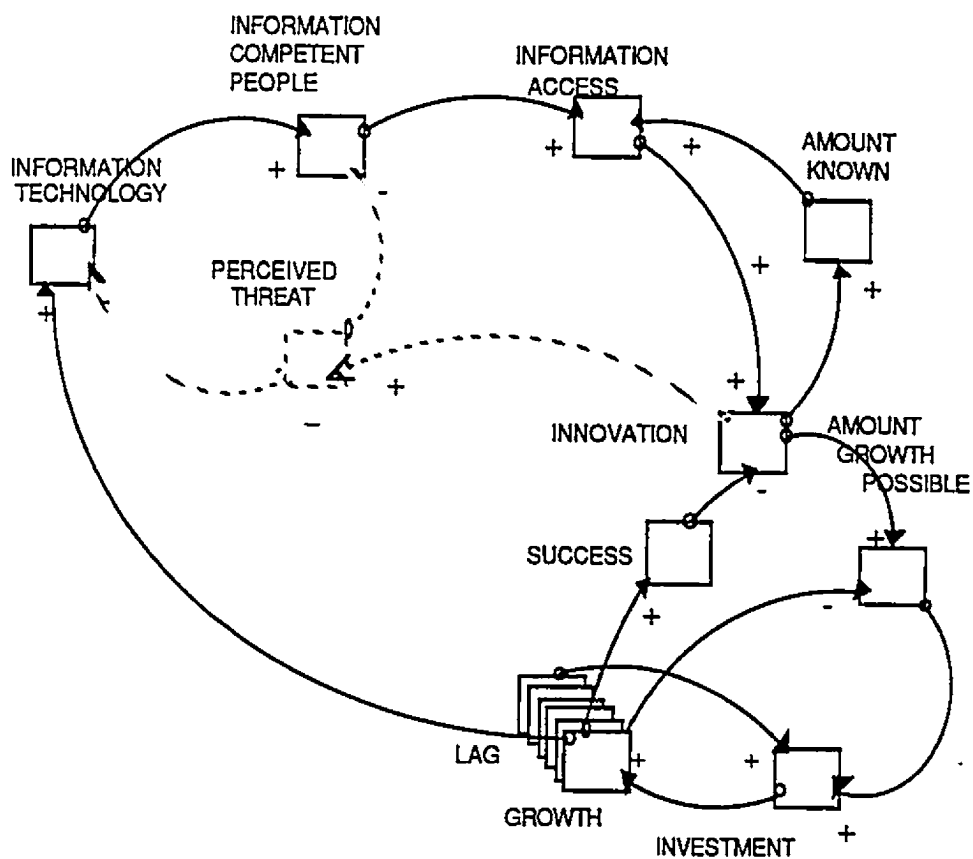

Figure 22: Weak threat: The link between innovation and sense of threat is weak and the economy is able to grow because of high information access and innovation.

phase growth will primarily be due to elite innovation and will primarily benefit the elite.

This innovation would tend to be along tried and true lines of development. This is partially because of the class of people who are innovating and partially because there is a tendency to base new ideas on existing ideas.

Second phase behavior of the social and economic system is different in different settings.

In settings where there is no competition and the information technology is controlled there will be a slowing of innovation and growth in the second phase leading to eventual stagnation (figure 23).

This also obtains in settings where there are a number of groups but only one group has the information technology. The first phase establishes the group's dominance over the entire area. The elite is defined as those who have control of or who have invented the technology. They maintain control of the entire area through information control, and development eventually slows and stagnates.

In settings where a number of groups are in competition for resources, growth will vary inversely with how much the use and benefit of the technology is restricted to the elite in each group. The groups that do not restrict information technology access to the elite

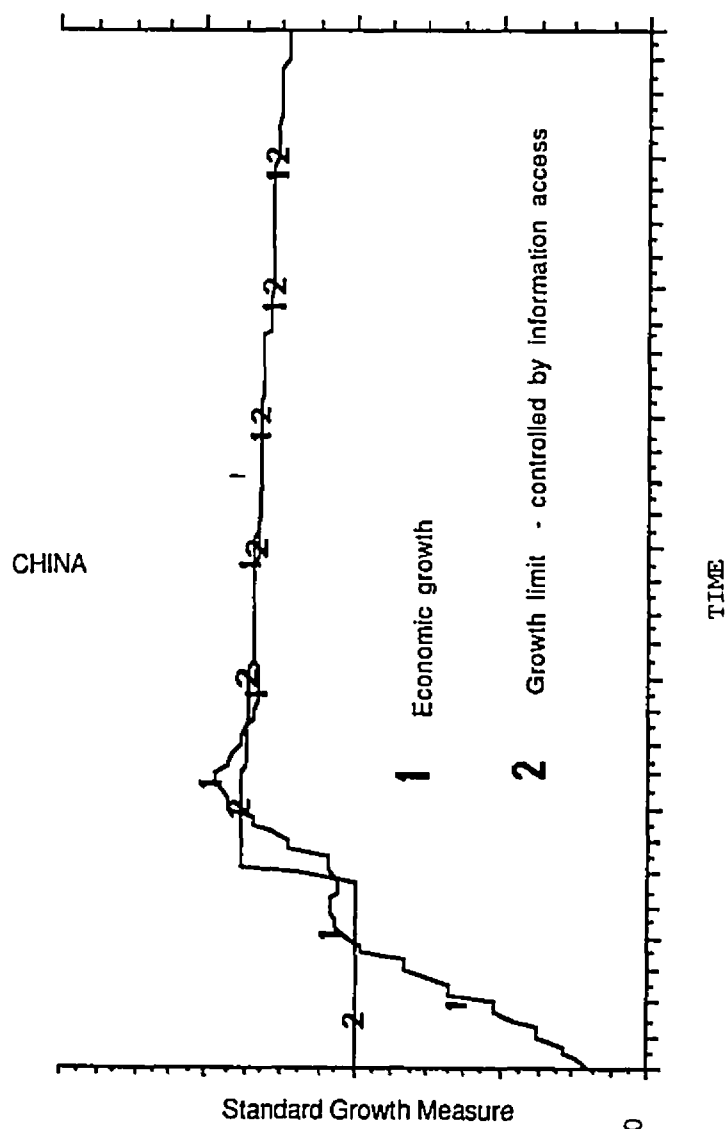

Figure 23: Graph: information controlled, non-competitive: because there is little or no competition the control of information and information access results in stagnation and lack of economic development. (China).

will establish economic dominance and will grow (figure 24). The groups which control information technology will be economically ruined because investment will tend to enrich those groups where information technology is not controlled. In the graph representing this condition shows that economic growth does not reach the limit and that both the limit and economic growth decline over time (figure 25). This occurs because investment goes elsewhere and information access and innovation per capita declines. Examples of the three contexts respectively are China, Spain and Holland.

This model is intended to show the relationship of information technology and economic growth. This assumes a link between economic growth and economic and social success. This relationship is very strong in some settings. In other settings success is more strongly linked to non-economic factors (Example 5). In these settings innovation will decrease even more rapidly.

Example 5

Spain	Success was strongly dependent on religious persuasion and family alliances
China	Success was linked to the Confucian civil service.
USSR	Success is linked to Communist party membership

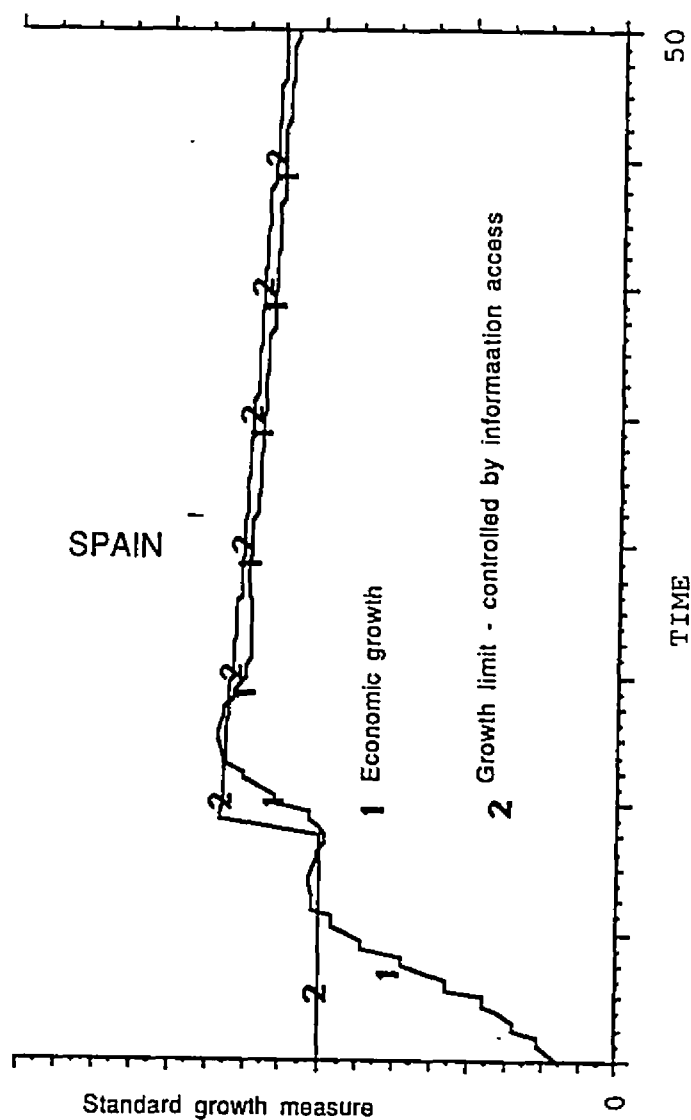

Figure 24: Graph: information controlled, competitive context: Because there is competition for resources the economy is rapidly ruined as investment goes to other countries in more innovative contexts. (Spain).

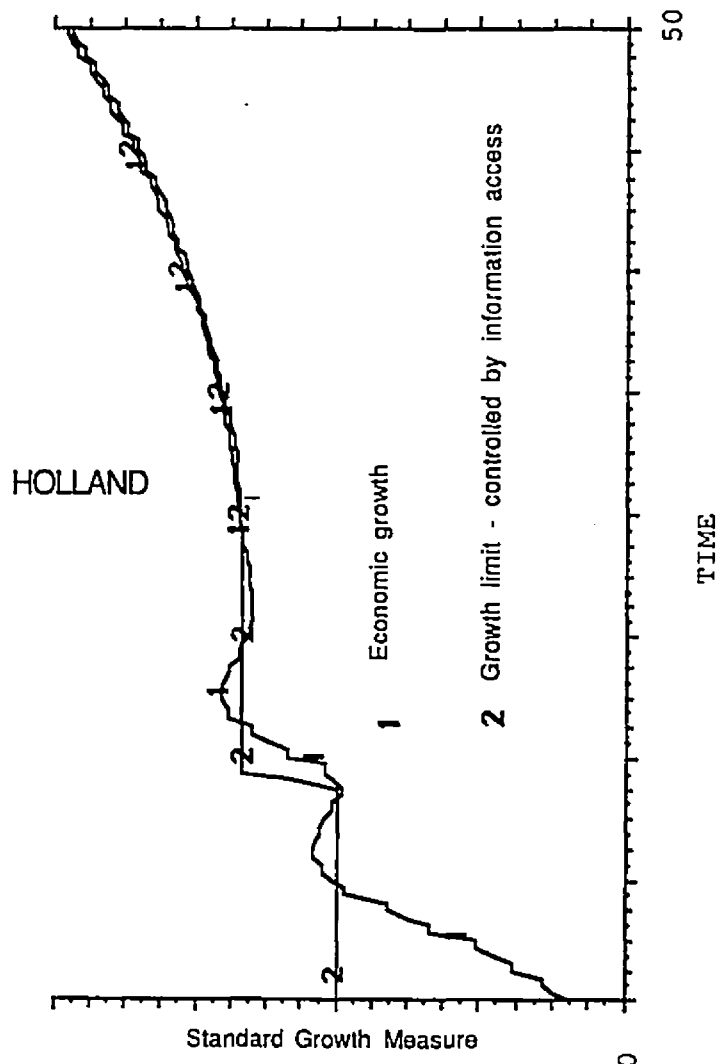

Figure 25: Graph: information not controlled: Here the economy develops because of high information access and high innovation. (Holland).

Implications of the Approach

Inherent in this modeling effort is the notion I have been developing since Chapter I, that systems grow until the limit of their information and their technology is reached. The growth of a system with a limit is shown in the graphs reproduced here as figure 26. The graph shows that the greatest amount of growth is at the beginning of the growth curve, when the system is dominated by the positive loop. As the system approaches the limit, it is dominated by the negative loop, growth slows and eventually stops.

If the limit is suddenly made bigger by some technological change, the system responds with a rapid growth spurt as the system is again dominated by the positive loop. This is illustrated in figure 27. This suggests that economic and cultural systems tend to function most of the time at the limit of their informational and technological capacity.

This, in turn, suggests several things: 1) The pattern of development shown in the archeological and historical record should be little or no growth before the introduction of new information or other technology, and rapid growth after its introduction, 2) That the individual members of the cultures are already making the

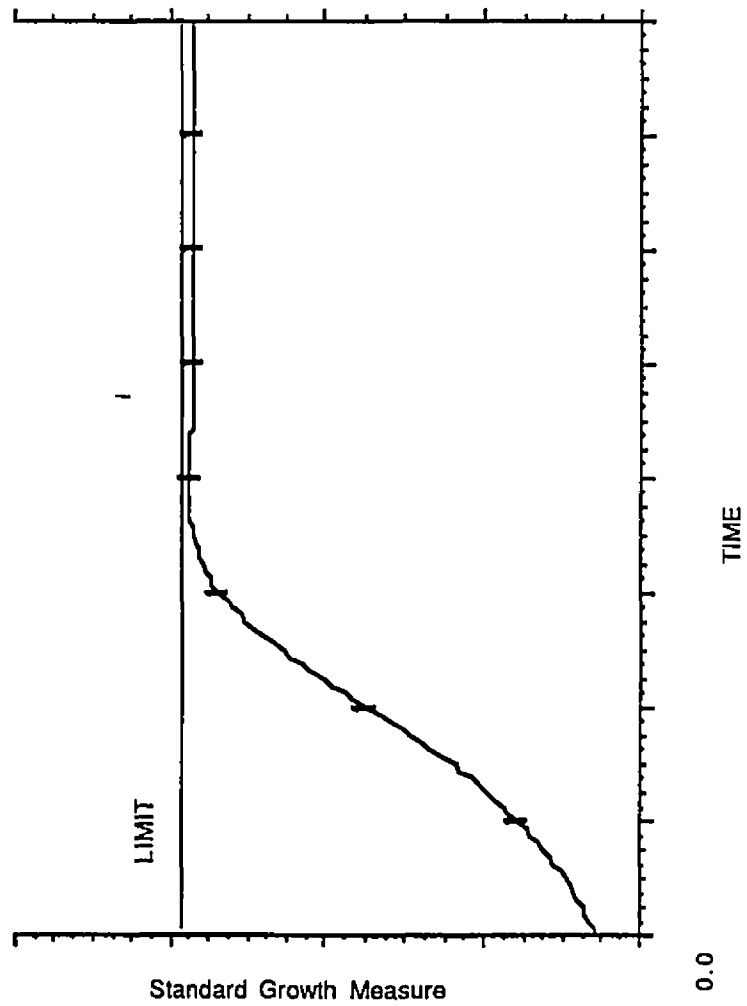

Figure 26: Graph: Most growth occurs at the beginning of the time period.

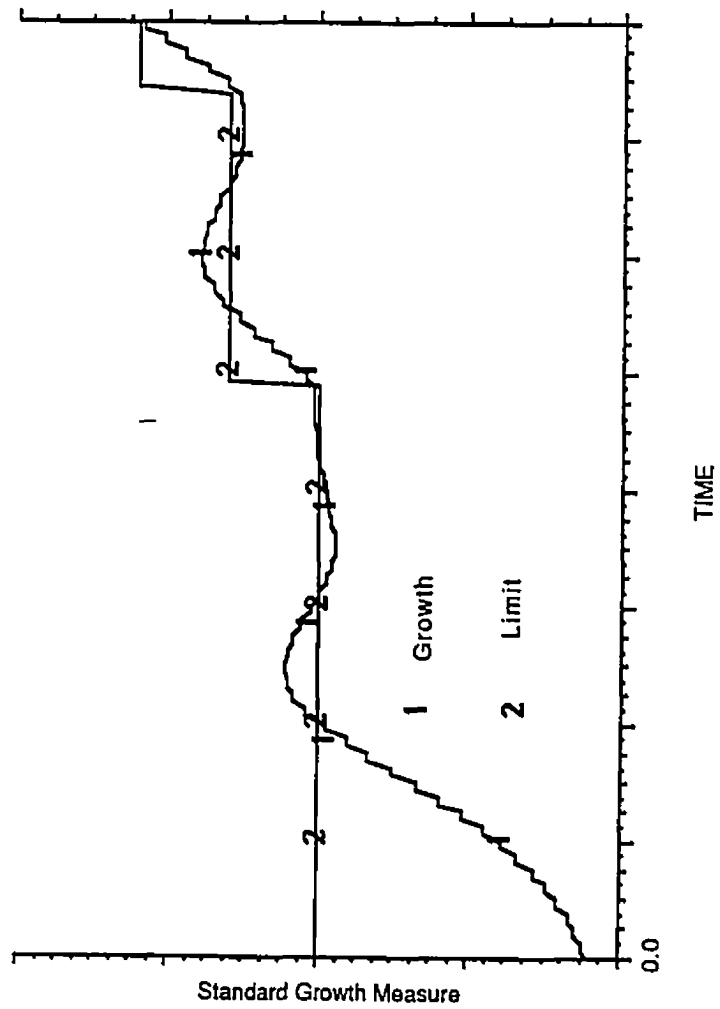

Figure 27: Graph: Effect of a raised limit on growth.

most efficient use of the existing technological and informational capacity, and 3) There exists some kind of natural unit size related to informational and technological capacity. (For examples see Appendix A)

In terms of the informal model this suggests that cultures grow up to their technological and informational limits and that it is these limits which keep the culture at equilibrium. The "unsticking" of the controls is a result of innovation which allows new growth. The observed "instability" occurs as the new limit is exceeded - **first phase behavior**. The severity of this instability is due to the amount of lag and the degree of simultaneity.

Rebuilding on the basis on new and old forms is different in different settings, **second phase behavior** depending on information access per capita.

PART II - Introduction

On the basis of the model as it stands we it is possible to predict which setting from a group of settings will benefit most from the introduction of an information technology - **supersystem behavior**.

To predict how economic growth happens it is necessary to think about what changes occur in the

successful setting - system behavior. This is attempted in the first section of this part of the chapter.

After developing some idea of what the system level changes are I will examine how information technology affects the individual and what she does which results in economic development. The examination of individual behavior is important because systems do not actually have behavior and are not capable of action. What is usually identified as system behavior is the result of the actions of individuals.

System Level Change and Economic Development

From part 1, above, I suggest that systems can only grow until they use up their unused growth potential for that type of system - they are limited by the amount of growth potential. To continue to grow it is necessary to increase the amount of growth potential.

Unused growth potential seems to change in discontinuous jumps associated with shifts in the organization of a culture. For example, the shift from hunter/gatherer life ways to early agriculture, or from the feudal manor to capitalism are shifts in the organization of society as well as an increase in the size of the social and economic unit. Observing these shifts in unit size

allows us to see that the amount of matter and energy processed by each individual increases as does the average number of individuals in each group.

From this perspective, system growth is defined as an increase in the number of connections or an increase in the flow of "stuff" through those connections. The organization of a system is defined as the pattern of connections.

In classical cybernetics it has been shown in simulations that an increase in the density of actual connections out of the set of potential connections in a network increases the likelihood that the network will be unstable (Ashby 1956; Ashby, 1981a; 1981b; Von Foerster et al, 1984). For example, a person wants to produce a product. If she needs to get three different things to make her product she is more vulnerable to some disturbance in the supply of materials than if she only needs one thing.

The classical antidote to instability is redundancy. For example, if there are two people each of whom needs three different things to produce a product and if the major source of disturbance is in the supply of material, if one person finds herself three suppliers of those three things she is more likely to produce the product than the person who only has one supplier of each of the three things. If I assume that the individuals have

the same ability to monitor - have the same channel capacity - the person with nine total suppliers is monitoring more relationships, using more channel capacity.

Redundancy is used here to mean extra - redundant - structures which keep something stable.

Another way of defining redundancy is as extra - meaning unnecessary - structures.

Taking the example above and changing conditions so that there is no disturbance in the supply of material then the individual who had three suppliers of each item would be using the energy to monitor - channel capacity - which could be used for something else. She could reduce the redundancy of her system and conserve channel capacity.

A change in the pattern of connections in a society is the result of a change in what connections are more redundant (Example 6).

Example 6

In pre-press European economies goods were produced within the family unit. Apprentices, journeymen, master craftsmen all lived in the same household. They were part of a social, geographical, moral, and domestic system as well as a production system. After the invention of the press and the spread of rationalized book keeping methods, the social, geographical, moral and domestic portion of that relationship was dropped. The master craftsman used channel capacity to monitor many craftspeople each of whom lived in their own households. The master craftsman created redundant connections to productive units and reduced redundancy in the domestic unit.

I suggest it is useful to think about the use of channel capacity in terms of a balance or a seesaw. One side of the seesaw has the amount of channel capacity, and the other has the things to be monitored and the amount of noise or entropy in the system. If the "things to be monitored" are shifted around, like in the example, there is still no change in how much total channel capacity is used. If there is a reduction in noise then more things can be monitored because more of the total channel capacity is available. In the example, the domestic, moral portion of the relationship between the master craftsman and the journeymen is defined as noise - as unnecessary to the functioning of the system. Again there is no change in the total amount of channel capacity.

This explains why one pattern of connections is stable at one time and another pattern of connections is at another time. It does not show how these shifts occur nor any relation between the shift in connections and information technology. To understand this it is necessary to examine the most micro level - the level of the individual.

Individual Level Change and Economic Development

If the system has been operating at or near the limit of unused growth potential for a period of time the knowledge of how things are done has become habitual. The individual is in the realm of habitual behavior. In this realm she interacts with portions of her environment, changing them to assure her survival, as part of her expression of herself. She does not see those interactions as separate from her experience of herself.

New technology can cause the interactions an individual has with her environment to emerge from the realm of habitual behavior. This occurs when the habitual ways of interacting with an environment do not work any more. This causes the interactions to emerge out of the background of habitual behavior so that she has to think about how the thing has been done and how the technology changes that interaction. The interaction stands apart from the person. It is alienated* from the person.

Information technology increases an individual's ability to communicate and/or to model something using abstract symbols (for examples see Appendix B). Modeling or communicating through a new medium creates conditions

*Note: I follow Marx's use, rather than modern usage. Alienate: To remove or dissociate, to make distinct or separate from oneself (Lat. *alienus* < *alius*, other)

which encourage the person to examine the information portion of what is being done (how a task or work group is organized, or what it is necessary to know and/or communicate) as if it were a "thing" which is separate from her experience of herself. It alienates the tacit experience she has of "how the thing is done" and makes that experience explicit.

Once the information aspect of something has been alienated it becomes a thing. Once information is a thing it can be thought about. If it can be thought about then the person can experiment with ways to improve it. When the person is happy with her improvements she can standardize them into algorithms, procedures or recipes. This simplifies them and makes them easier to communicate and to generalize to work in other settings. This reduces the amount of noise in the system. Once the new things known or the new ways to organize or communicate have been generalized, they can be specialized to fit the new settings. Over time these new ways are institutionalized and become part of the realm of habitual behavior.

This process - alienation, examination, experimentation, standardization, generalization and re-specialization - encourages individuals to allocate more channel capacity to those tasks which have emerged from the realm of habitual behavior. Information technology reduces

noise in the system through simplification and ease of communication. This makes more channel capacity available to monitor more relationships. Part of that increase available channel capacity is directly the result of information technology - that part which deals specifically with the management and communication of information - the other part comes from environmental interactions which are part of the realm of habitual behavior and have not been alienated (Example 7).

Example 7

In pre-press economies the family was a productive as well as a reproductive unit. Women participated in the production process. Wives of masters were the second in command so that if the husband died the entire unit could continue (redundancy maintaining stability). Women, especially widows, ran every kind of enterprise and belonged to and voted in guilds. Men and women both participated in the training and supervision of all the members of the household as part of their productive and reproductive life.

In post-press economies the reproductive unit - family relationship was less redundant. The craftsperson was now specifically a man. The education of apprentices and the supervising of journeymen which had been major part of a woman's contribution to the production process had to be redesigned as production moved out of the home. The channel capacity which men had devoted to their own children and apprentices was now devoted to supervising many workers.

The relationship between men and women became less redundant, and less equal as both were isolated by their respective roles. The production system became more redundant and therefore more stable. Over time the new organization of society became institutionalized. The new social relations were seen as natural. This changed the perceptions of what it meant to be a man or a woman. Women became identified with home, privacy,

interiorness, emotion and biologicalness. Men became identified with business, publicness, exteriorness and mind.

I suggest it is useful to think about this in terms of the see-saw. It is possible to see that the craftsman and his wife each have an amount of channel capacity which they have allocated to the tasks relating to production and reproduction. As the craftsman alienates the tasks relating to production and allocates his channel capacity to them, his wife has to allocate more of her channel capacity to the tasks which have not been alienated, to keep the see-saw in balance.

Thus there are two ways that information technology increases channel capacity devoted to the production of economically measurable wealth which in turn changes the amount of unused growth potential: 1) an increase in available channel capacity allows an increase in the number of connections and more efficient monitoring of the flow of material and energy through those connections; and 2) re-allocation of channel capacity to the environmental interactions which have to do with production from those interactions which have to do with non-economic tasks (interactions which have been alienated from the environmental interactions which have not been alienated).

Two caveats: 1) the alienation of environmental interactions need not be related to information technology. The relationship to information technology is a special case of a more general phenomena which deals specifically with the kind of environmental interaction we identify with knowledge and organization; and 2) in theory the re-allocation of channel capacity to the environmental interactions which have been alienated need not be in the direction of increasing connections.

Putting it together - The individual and the system

I propose using the notions of redundancy and connection to create a model of how systems grow and develop.

We can think of an economic system as a group of individuals each one of whom takes stuff from the person ahead of her, does something to the stuff, and then passes it on. Each pass is a connection.

If the system is small enough for each of the members to see each of the other members, the group can regulate its activities so that the stuff is passed smoothly - regulation is implicit and in the realm of habitual behavior.

As the group gets bigger and bigger, more and more connections are added and it gets harder and harder to keep things moving smoothly because there are more and more chances of some problem occurring at one of the stations which then affects the whole group.

The way to avoid instability is to increase redundancy. If no way is found to increase redundancy the system will stop growing at this point. This defines the limit of this kind of a natural unit. We can think of it as analogous to the hunter/gatherer band where regulation is implicit and there are no identified leaders.

The group can continue to grow by adding more connections if it adds a regulatory layer - music or the beat of a drum - to keep the timing. Regulation of the system has become explicit. This is an example of redundancy of communications. It is regulation by a centralized authority. This is analogous to a early kin-based agricultural group where there is some leadership which has emerged from the kin group but it is not formalized and compliance is voluntary. This defines another natural unit.

As the system gets bigger and conveyor belts are used to pass around the stuff, then any hitch at any of the stations results in an Abbott and Costello type of pile up of stuff. The centralized authority may increase the

redundancy of the regulatory segment of the system by having supervisors, and overseers of the supervisors - redundancy of design. This is analogous to the emergence of the first city-states. Production, division of labor, and leadership is formalized. Compliance to authority is enforced through legal as well as social sanctions.

The limit to this form is the channel capacity of the supervisors and the overseers of the supervisors. If their channel capacity is enhanced through the use of information technology the size of the entire unit can be enlarged. This is analogous to the invention of writing and the emergence of empires. Compliance is enforced with force, and a defined class system which may include slavery emerges.

At some point the size of the system grows to the limit of the centralized regulation system. Then the system either breaks down or stops growing. Where the centralized control does not break down the size of the empire is limited. This is what happened in China. Where the empire manages to continue growing, the control mechanisms break down. This is what happened to the Roman empire and what we may be seeing in the USSR.

For the system to continue to grow it is necessary for control to pass to the individual at each node or station in the network. This is analogous to the beginning

of decentralized economic and political control of the Middle Ages. Once this decentralization has occurred, each of the individuals responsible for the station can insure its stability if she can continue to pass stuff. This can occur if she increases the redundancy of the relationships she needs to continue. She can pursue a number of strategies separately or in combination. The various forms of redundancy are useful against different kinds of disturbance.

For disturbances in the flow of material goods:

Redundancy of material (inventory) - She can build up a stock pile of material so that she is buffered against instability "up stream" and she can build up a stock pile of finished goods to guard against fluctuations in demand "down stream".

Redundancy of material (alternate sources) - She may identify more than one source of material, and more than one individual to give material to.

For disturbances within the process at her node

Redundancy of design (standardization) -

She may clone herself such that one of the clones is just in charge of taking things off, one is in charge of doing the something, and one is in charge of putting things on the next belt - professionalization.

She may standardize the parts of the process or the material being worked on.

She may standardize relations with others in the form of contracts.

She may standardize her approach or method of interacting or gathering information.

For disturbances of all types

Redundancy of channel or communication - She may make a deal with her neighbors or her clones to shout if there is a hitch so she will be prepared to correct. Wherever there is a need for more stability, redundant communications channels will help her to increase the stability of her operation by allowing her to identify options, improve feedback and allocate resources.

In terms of economies or organizations, the most difficult shift in control is between centralized control and control by the individual stations. This is a shift in organizational structure and existing redundancy keeps the old structure stable. The individual, acting locally, increases redundancy in the system and allows the size and the complexity of the system as a whole to increase. (For examples see Appendix C)

Application of the Model

On the super-system level it should be possible to predict which setting will benefit most from the introduction of an information technology.

On the system level it should be possible to see increased connections and a change in the pattern of connection - reorganization - in the settings with the highest saturation of information technology.

On the individual level it should be possible to see increasing specialization and professionalization which is the result of the alienation of information. It should be possible to identify things which had been considered to be intrinsic to the individual as part of their person become modeled, standardized and taught.

Over all it should be possible to identify two phases of impact. During **first phase impact** it should be possible to identify growth and elaboration of existing organizational structures by existing elites who have increased access to information. During **second phase impact**, in settings where there is high information access by new classes, new organizational forms based on the alienation of activities which previously were thought to be inherent in the individual should be observed.

Chapter VI

ECONOMIC DEVELOPMENT AND CRISIS

Introduction

In considering the application of the model to the impact of the press it is necessary to trace the impact of the press in two time dimensions separated by some kind of economic turn down or instability - first phase and second phase, and three levels of behavior - supersystem level, system level and individual level: macro to micro.

During first phase impact at the supersystem level, there should be, rapid economic growth. At the system level this should be essentially the same in each setting. This economic growth should be based on innovation which allows expansion and elaboration of existing organizational structures by members of the elite resulting in an increase in connection. At the individual level, where there is information access, there should be increasing standardization, specialization and professionalization which is the result of the alienation

of information. Things which had been tacitly considered intrinsic to the social individual should have become separated from the social role. First phase growth should terminate in a recognizable downturn due to an overshoot of the limit for that form of organization.

During second phase impact at the supersystem level there should begin to be impacts of differential information access in different settings. At the system level in settings where there is high information access there should be economic growth associated with new innovation. In settings with low information access there should be economic stagnation and decline. In settings with intermediate information access there should be an intermediate condition. At the individual level, where there is information access, there should be increasing standardization, specialization and professionalization which is the result of the alienation of information. There should be things which had been tacitly considered intrinsic to the social individual become separated from the social role.

Overall it should be found that the settings which experienced economic growth due to innovation first will become conservative first because success tends to decrease innovation.

In short, wherever there is access to information (amongst the elite of all countries and amongst all classes where information access is not controlled) it should be possible to observe the local affect of centralization, standardization, specialization, communication and control. The greatest wealth should be observed in global settings which have the least centralized control of information because they allow the most access.

Overview - The story thus far..

Before the press, Europe's economy was a combination of manor economies and small cities. Politically there was a hierarchical network of alliances based on hereditary social position. In theory every person owed fealty to someone from the lowest to the highest. In fact there was little actual control.

The Church had the most effective organization. It was the only institution able to control information access. The tithe was a direct tax on the wealth of the citizenry. This made the Church independent of the political system. The Church benefited from the wealth of the lay population. Because of this and its monopoly position it did not need to control information access.

With the Reformation the Church lost its monopoly position. The Inquisition and the Counter Reformation restricted information access, burned books, smashed presses and persecuted printers. The Church also made political alliances, and many of the ablest ministers of the early Renaissance state were churchmen.

There had been slow but a continuing trend toward urbanization and centralization. Guilds controlled the towns and cities. The most impressive pre-press economic growth was in the Italian city states. This makes sense in terms of information access since Italy was the seat of the Church.

Before the 16th century cities were able to hold their own against the centralized state government. But throughout the 16th century the city-states had to contend with the rise of the absolutist, Renaissance State financed by colonial wealth and administered by professional bureaucrats.

Calling the Shots

The countries which maintained the closest ties with the Catholic Church limited information access during the Counter Reformation by burning books, controlling what was printed and persecuting printers. As a consequence

many printers moved to Holland and Switzerland where the press was not controlled. England became a Protestant country during the reign of Henry VIII but reverted to Catholicism under Mary. France remained loyal, but was less closely tied to the Church than Italy, Spain or Portugal and was less repressive.

The implication is that there will be economic growth as second phase development in Holland and England. Development will be earlier in Holland than in England. Because of this I would predict that Holland will become conservative before England.

During the second phase for the Catholic countries, Italy, Spain and Portugal in decline and France will be in an intermediate position.

First Phase Impact

Trevor-Roper (1963) notes that although the Renaissance started as a city phenomena it grew to be a federal phenomena during the economic expansion of the 16th century. This economic expansion was based on colonialism. But colonialism alone is not an explanation. Conquered of territory is not profitable unless it can be exploited. The economic and political expansion had to be administered, managed and financed. The independent

cities, which were such a feature of the late Middle Ages and early Renaissance, did not have the organizational form which would permit them to manage colonial expansion. This was possible in the Royal Courts because they had access to capital and able ministers who could invest that capital in exploration and exploitation.

...all through the century the number of officers was growing. Princes needed them, more and more, to staff their councils and courts, their new special or permanent tribunals which were the means of governing new territories and centralizing the government of the old. It was for this reason that the Renaissance Princes and their great ministers founded all those schools and colleges. For it was not to produce scholars, or to advance learning or science, that old colleges were reorganized or new founded by Cardinal Ximenex or Cardinal Wolsey, by Henry VII of England or John III of Portugal or Francis I of France. The new learning, it is notorious, grew up outside the colleges and universities, not in them. The function of the new foundations was to satisfy the royal demand for officers - officers to man the new royal bureaucracies - and, at the same time, the public demand for office; office which was the means to wealth and power and the gratification of lavish, competitive tastes (Trevor-Roper, 1963, p.78)

Thus the Renaissance state was an organizational shift from a loose network of cities based on alliances for mutual defense, to a formalized bureaucratic state - an increase in connection. Schoffer (1979) writes of the growth of state centralization in the 16th century:

The intensifying of traffic and trade, the new technical possibilities of administration and planning, the national disruption of the Church, the

economic interweaving of towns and areas within the boundaries of the State are part of the picture of systematization of authority and the growth of larger political units (Schoffer, 1979, p.102).

This relates to the press in that the notions of administration, management and statesmanship based first on the classics - Plato, Aristotle - and then created by contemporaries - Machiavelli's *Prince*, Moore's *Utopia* - were readily accessible because of the press. Members of the elite were made aware that statesmanship was something which could be written about, taught and learned.

The model suggests that the larger organizational unit did not arise out of the cities because cities were successful and success is conservative. The cities did not need to innovate or to think about their organizational structure.

It was not that the rich and well-born loved royal centralization for its own sake, but their love of order was mostly a sensible and deliberate self-interested calculation. Citizens and nobles might seek to find their own good in the new and old institutions of centralizing power. In the court, army, counting-house and Church they saw their chance to preserve, or preferably to enhance their own power and riches (Schoffer, 1979, p.102)

The Royal courts with their Church educated ministers were able to innovate and to expand. The mechanism was redundancy of design - more officers to man bureaucracies

to administer more territory - make more connections - and thus generate wealth.

This is the positive feedback loop which drives the incredible expansion of the 16th century.

...increasingly as the seventeenth century succeeded to the sixteenth, this multiplication of ever more costly offices outran the needs of State. Originally the need had created the officers; now the officers created the need...But whereas today such inflation is curbed by the needs of the Treasury, in the sixteenth century the needs of the Treasury positively encouraged it. For offices, in the sixteenth century, were not granted freely: they were sold... So 'the Renaissance State' consisted, at bottom, of an ever expanding bureaucracy which, though at first a -working bureaucracy, had by the end of the sixteenth century become a parasitic bureaucracy...(Trevor-Roper, 1963, p.82).

The picture painted by Trevor-Roper is that, during the 16th century, there was a simultaneous expansion of the economies all over Europe, and that this was a bureaucratic expansion which was essentially similar regardless of setting.

The model suggests that this feedback loop has a limit. It also suggests that there will be an overshoot which will be exacerbated by the affect of simultaneity and the Soros effect.

Already, by 1590, the cracks are beginning to appear. The strains of the last years of Philip II's wars release everywhere a growing volume of complaint... for of course, although war has not created the problem, war aggravates it...but if the strains are already obvious ... they are, as yet, not fatal: for

peace comes first...And then, with peace, what relief! The overstrained system is suddenly relaxed, and an era of pleasure and renewed extravagance follows... How, we may ask, could it go on? Even a far less expensive, more efficient bureaucracy had only been saved by peace: how could this much more outrageous system survive if the long prosperity of the sixteenth century or the saving peace of the seventeenth should fail.

In fact, in the 1620's they both failed at once...by 1621 the wars of Philip II had been resumed, bringing in their train new taxes, new offices, new exactions. Meanwhile the European economy...was suddenly struck by a great depression, the universal 'decay of trade' of 1620. (Trevor-Roper, 1963, p.84)

In terms of the model this marks the end of the first phase of growth based on expansion and elaboration of existing organizational forms - system behavior. This was possible because the newly organized universities trained members of the elite to become professional bureaucratic managers - individual level behavior. The pattern of runaway growth, overshoot and downturn which is essentially the same regardless of setting - supersystem behavior is as the model predicted.

This is sufficiently surprising, from the perspective of the end of the 17th century, when Spain was in decline, Holland was in her Golden Age, and England was beginning to establish her dominance. If the cause of the growth is attributed to the impact of the press, it makes sense that the effects - redundancy of design in the form of an expanding bureaucracy, staffed by professionals who

could oversee the redundancy of regulation which occurs with centralization, using written communication to create redundancy of channels - should impact the elites in different countries in a similar manner, and within a similar time period since their access to information, and information technology, was equivalent and simultaneous.

That this was a new development is supported by Steensgaard (1978) in his presentation of the various crises of the 17th century, revolutions, protests, etc. as a reaction to the new demands of the absolutist state.

The different reactions in different countries, regardless of whether or not it came to armed conflict, or whether the protests led to any results, depended on the social and economic situation of the country in question... But in every case it was the governments that acted in a revolutionary manner: the tax demands disrupted the social balance. They did not create a revolutionary situation: they were the revolution... Behind the symptoms of economic crisis, and behind the internal conflicts in the European countries in the middle of the seventeenth century, we find the same factor: the growth of state power and the increased fiscal demands. (Steensgaard, 1978, p.44)

Thus observations at the supersystem level of: 1) The economic expansion of the 16th century followed by 2) The crises of the seventeenth, is predicted by first phase behavior of the model presented in chapter five - expansion and collapse.

At the system level the economic growth is essentially the same in all settings. It is based on

innovation and elaboration of existing organizational structures - innovation in war - colonialism; innovation in administration - bureaucratization of government. This was done by the members of the existing military and political elite and resulted in an increase in connection between the centralized government and the rest of the territory which had previously been loosely administered locally and an increase in connection to the rest of the world through trade and colonial conquest.

At the individual level the officers which were such a feature of the Renaissance State were specialists and professionals educated in the new Universities. This is a shift from the loose network of quasi-military, quasi-social alliances of the medieval period. During the medieval period the qualities of service were thought to be part and parcel of the person and were inseparable from the perception of that person as a social individual. In the Renaissance state, offices were bought and sold and officers and ministers were taught - their activities were no longer part of their social role.

Now it is possible to go on and examine the different reactions to the first phase growth by examining the system level behavior. This is similar to what Steensgaard is referring to as different economic and social situations above.

Second Phase Behavior

The model suggests that as new people gain access to information they will have a tendency to innovate based on their existing experience of the world. The elite innovated within the spheres of government, colonial administration and war. Where the lower classes have high information access they innovate within their area of expertise. This results in a pattern of economic growth based on innovation which follows the pattern of increased information access. Where settings are in economic competition the setting with the least information access will be poorest and the setting with the most information access will experience the most growth.

Spain - Control of Information Access

Spain had the least information access of any country in Europe and she was in economic competition with other countries. On the plus side Spain had able ministers and capital in the form of New World gold and silver. The model predicts that Spain experience a dramatic economic decline during the second phase of development. There should be no structural change in the connections

maintained by members of the lower orders and little or no innovation based economic growth.

Trevor-Roper (1963) gives evidence of the condition of Spain's economy. He states that Spain implemented neither court reform nor mercantilist policies despite the advice of the *arbitristas* (economic philosophers), instead Spain was involved in war, which increased the burdens of state:

Nor had the Spanish economy been enabled to bear it. For meanwhile the national wealth of Spain had not increased: it had diminished. The voices of the mercantilist were stifled. The trade of Spain was taken over almost entirely by foreigners (Trevor-Roper, 1963, p.93)

The picture of Spain painted by Gonzalez de Cellorigo in 1600 and quoted by Elliott (1967) fits the prediction of the model:

Our republic has come to be an extreme contrast of rich and poor and there is no means of adjusting them one to another. Our condition is one in which there are rich who loll at ease or poor who beg, and we lack people of the middle sort, whom neither wealth nor poverty prevents from pursuing the rightful kind of business enjoined by Natural Law. (Elliott, 1967, p.196)

Throughout the Iberian peninsula the story was the same. Valencia's economy was dislocated by the expulsion of the Moriscos. Catalonia's traditional trade with the Mediterranean was contracting. Portugal's Far Eastern Empire lost to the Dutch and inroads being made on

her Brazilian Empire. And increasingly the galleons sailing from Seville carried foreign goods (Elliott, 1967). Thus in all of Iberia the economic sector was becoming less rather than more connected.

This decline was not due to any intrinsic fault in the Iberian character. Elliott points out that there was no such shortage of "people of the middle sort" in 1500 but that they had bought themselves into the peerage as was the case throughout Europe. However in Spain the people of the "middle sort" were not replaced.

The model would suggest that Spain's persecution of the press restricted the non-elite population's access to information, and therefore denied them the means to develop economically, or technologically. This explains the lack of the "people of the middle sort" lamented by Gonzalez de Cellorigo. Because Spain was in competition with countries where information access and technology was not controlled she suffered because she could not compete.

That this is due to Spain's attitude toward information access is supported by Elliott who writes:

Why was it that science and technology failed to take root in Spain at a time when they were beginning to arouse considerable interest elsewhere in Europe?...The conscious transformation of Spain into the redoubt of the true faith...served to cut Spain off from that powerful intellectual current which was leading elsewhere to scientific inquiry and technical experiment.(Elliott, 1967, p.198)

The evidence from Spain supports the model presented in the previous chapter.

Holland - No Control of Information Access

Holland has been the prototype of the "free press" setting. There was no control of information technology and during the Reformation printers left the Catholic countries (especially Spain) to make their livings in Holland. So the Dutch press had more printers per capita earlier than other countries.

The earliest second phase behavior - economic growth based on innovation by individuals who are not members of the elite - the "out group" occurs in Holland. In addition, because people go from the known to the unknown I suggest that there should be similarities between the activities and organizational structures which generate wealth in Holland to the way wealth was generated in the Italian city states.

The history of what was the Spanish Netherlands shows that she rebelled against the absolutist Burgundian court early - beginning in 1566. The "out group" became the "in group" and based the wealth of the Dutch Republic on what has been called by Modelski (1987) a revolution in banking and finance. The trend toward centralization and

colonial expansion benefited merchants rather than the Royal Court.

Trevor-Roper (1963) uses Holland as an argument against the Marxist position that economic development is due to a "bourgeois" or "capitalistic revolt.

Moreover, if accident rather than design had rid the United Provinces of the Renaissance State, policy had also achieved there the other, economic reform ... It was not that there was a 'bourgeois' or 'capitalist' revolution in Holland. Dutch industry was relatively insignificant. But the new rulers of Holland, seeking the means of guarding their hard-won freedom, set out to imitate the fortune and the methods of those older mercantile communities which preserved their independence by rationally combining commercial wealth and maritime power (Trevor-Roper, 1963, p.95).

The Marxists concur that Holland was not a leader in capitalist manufacture Hobsbawm writes:

But the greatest beneficiary of seventeenth-century concentration, the Netherlands, was in many respects a 'feudal business' economy; a Florence, Antwerp or Augsburg -on a semi national scale. It survived and flourished by cornering the world's supply of certain scarce goods and much of the world's business as a commercial and financial intermediary. Dutch profits did not depend greatly on capitalist manufacture. Hence the Dutch economy to some extent did a disservice to industrialization in the short run: to their own, by sacrificing Dutch manufactures (until 1816) to the huge vested interests of trading and finance (Hobsbawm, 1967, p.45).

This supports the contention that success is conservative. Holland, having found a way to achieve economic prosperity was reluctant support the new "out

group" - manufacturers. This also indicates that there were Dutch manufactures to be sacrificed. The "out group" in Holland were continuing to innovate but the previous innovators, the financiers who were responsible for the revolution in banking and finance, had become the conservative "in group".

France - Intermediate control of Information Access

The model has predicted that France would be intermediate between economic ruin of Spain and economic growth of Holland and England. Of France Trevor-Roper writes, that although it had an unsuccessful revolution in the Frondes, the monarchy there was not like Spain's:

It was not economically parasitic. Industry, commerce, science flourished and grew in France, in spite of the 'failure' of the 'bourgeois revolution', no less than in England, in spite of its' success'. To all appearances, in 1670, in the age of Colbert, absolutism and the *ancien regime* were perfectly compatible with commercial and industrial growth and power (Trevor-Roper, 1963, p.95).

I noted above that Holland's wealth was based on innovation in the realm of banking and that she had become conservative and did not encourage the new "out group" manufacturers. This picture of Dutch manufacturers who are not supported is very different than Colbert's France,

where it was necessary to establish a policy of fostering industry.

This policy of industrial investment combined with France's weak control of the press, combine to give France her intermediate position. Dobb (1963) writes that Colbert's policy fostered some industrial investment:

But in general the system of industrial monopolies was cramping and restrictive, both by reason of the exclusiveness of the patent rights that were granted and by reason of the narrow circle to which the grant of such rights was generally confined. (Dobb, 1963, p.165)

Thus, France is in an intermediate position economically but it is due to the actions of the elite, who have information access, rather than to innovation by the "out group".

England - No control of Information Access

England, for the most part, did not control access to information. The qualification is necessary because during the reign of Mary Tudor (Bloody Mary) there was persecution and information control as she tried to return England to Catholicism. This had the affect of getting England off to a slower start on phase two.

In the long run this was beneficial to England because the earliest innovation in Holland, was based on the Italian City States mercantilist model. The mercantilist of Holland had already "cornered the banking market". England had to find a different path to prosperity.

That the countries of Europe were in a competition should not be overlooked as noted by Steensgaard (1978)

This complementary relationship, so obvious at the time, has perhaps been underestimated by the historians of our age who are more used to analyzing economic life in terms of growth or fluctuations. The decades in the middle of the century, when the greatest economic difficulties were to be found in Spain, Germany, France and England were at the same time the golden age of the Netherlands. When the Dutch trade began in the last years of the century to show signs of weakness... there were others prepared to step in: the advance of English foreign trade after 1660 is a well known phenomenon. (Steensgaard, 1978, p.36)

The basis for England's economic growth was her production of new draperies and her ability to compete with Holland because of her lowered production costs (Steensgaard, 1978, p.33).

The strength of the English economy, not the state of the court, was responsible for her economic growth. There is evidence of this in two things: First her government was unreformed and yet she prospered economically. Trevor-Roper writes:

Thus, in 1640 the English Court, like the Spanish, was still unreformed. But what of the English economy? Here the parallel no longer holds... The early Stuart governments did not ignore matters of trade... By their financial methods, whether deliberately or not, encouraged the formation of capital, its investment in industry... The years of their rule saw the growth of English capitalism, sponsored by them, on a scale unknown before... For in 1640 the leaders of the Long Parliament did not seek - they did not need to seek - to reverse the economic policy of the Crown. They sought one thing only: to repair the administration... to abolish monopolies, wardships, prerogative taxes, cut down the 'waste', and establish the Stuart Court on a more rational, less costly basis (Trevor-Roper, 1963, p.99).

And second the court sponsorship of capitalist monopolies was unsuccessful. Dobb notes that favorites and petitioners of the King received patents and monopolies to develop certain industries. Of these he writes:

The result was a curious paradox. A practice, which on the face of it represented a bestowal of royal favor and protection upon industry, in fact aroused the opposition of industrial interests, and acted as a brake on the development of capitalist production. (Trevor-Roper, 1963, p.165)

Thus, governmental support for manufacturing was not what fostered the development of capitalism. The model would support this since it would suggest that the granting of contracts and patents to members of the existing elite tends to support conservative rather than innovative actions.

In England, the "out group" had begun to affect a revolution in the methods of production. In order to

examine this more closely I suggest a shift in focus down to the individual level.

Before the press and the spread of literacy, there was little distinction between domestic and income producing tasks. The family was a productive as well as reproductive unit. There was little business/home distinction.

A craftsman's wife was the second in command. If the craftsman died the entire unit could continue. In guilds widows took over the voting rights of their husbands. The vote belonged to the unit, the husband was the agent for the whole. Women belonged to guilds, made contracts, ran and worked at every kind of enterprise. (Boulding, 1976)

A journeyman became a master by marrying a woman from his guild without whom he could not run his business (Boulding, 1976; Miskimin, 1969).

Apprentices and journeymen did domestic tasks as well as producing goods for sale. Men and women participated in the care and training of children as a normal part of the supervision of the household. The household was the focus and the foundation of the economy. Master, mistress, journeymen, apprentices, serving wenches and children lived, worked, ate, and slept in common concern for the welfare of the whole. There was no

public/private distinction. There was little adult/child distinction (Postman, 1982).

In an unstable world this made great sense. If times were hard they all ate more bread. If times were good they all ate more meat and drank better wine. And at all times they all worked. There was no labor/leisure distinction.

This world view makes no distinction between the individual as a worker or producer and the individual as a member of a social group. The journeyman or serving wench worked at their tasks because of where they were in the social circle not because of the money they were paid. Their labor wasn't for hire. A contract between a master and apprentice or journeyman was an agreement to a social relation out of which production occurred.

The press brought literacy and book keeping methods to common people and changed the face of society. It emphasized some aspects of life at the expense of others.

Once people could read, count and keep track of the amount of material they needed and the amount of product they sold it became apparent that some tasks were more lucrative than others. Maintaining a journeyman to swill the pigs, or mind the baby didn't pay. Counting made it possible to plan and contracts made the future more secure. The tasks related to production were alienated from the

person as a social individual. The flexibility of the common table and the common household was less necessary.

As tasks related to production for sale emerged from the background of household activities domestic tasks became less visible. Tasks related to production of goods for sale became alienated by the act of accounting. The notion of labor became associated with tasks done for money.

Accounting made control more automatic. Before accounting, masters knew if a journeyman or apprentice was working because they all lived together. Control was tacit and social. Accounting made it possible for a master to track of how much stuff was produced without actually watching to see it done. This simplified the master's task - reduced noise - and allowed him to monitor more journeymen - re-allocate channel capacity to monitor redundant production units.

Business moved from the common room, to a room of its own, to a floor of its own, to a separate building (Chapelot & Fossier, 1985; Schema, 1987). With each move women became more and more identified with the background, the back quarters, the home (Boulding, 1979). This began the distinctions - business/home, public/private, interior /exterior.

Before the press the social world was divided horizontally, by class. Information and education belonged to the elite. After the press, the world was divided vertically, by gender. More men of all classes had more access to information and if they could use it to their advantage they could be socially and economically mobile.

It is important to notice the change in how society was divided because this allows shows that the channel capacity of the mastercraftsman and his wife did not increase, the allocation of it changed. Women became specialists in the tasks relating to reproduction and men became specialists in tasks relating to production. This is an evolved cultural distinction not a biological distinction. This shows that the development of capitalism was also the development of the economic marginalization of women. And that these are complimentary developments which are dependent on each other. The first craftsman to hire many journeymen to do piece work within the paradigm of hired labor power was able to do so because his wife took over his responsibilities at home.

Looking at the evidence of England's economic condition Dobb states, in his work on the development of capitalism, that in England there were various forms of investment in industry and manufacture. Much of the most effective development occurred where well to do craftsmen,

of various industries, began to innovate in the organization of the manufacturing process by beginning to hire others. He writes:

The opening of the seventeenth century witnessed the beginning of an important shift in the centre of gravity: the rising predominance of a class of merchant-employers from the ranks of the craftsmen themselves (Dobb, 1963,p.134)

Quoting a manifesto written by the middle and small craftsmen of the feltmakers who were protesting the practices of the wealthier members of their guild, he writes:

...many of the trade employ ten, twenty or thirty persons, and upwards in picking and carding wool and preparing it for use, besides journeymen and apprentices (Dobb, 1963, p.137)

This indicates that the wealthier feltmakers were innovating in ways which were not sanctioned by the rules or traditions of the guild. It also indicates that the kind of innovation which was taking place was a kind of division of labor and that that labor was wage labor instead of the traditional apprentice or journeyman labor. This seems to indicate that these wealthier members of the feltmakers guild were becoming industrial capitalists on a small scale. It also indicates that the way in which this was occurring was through the increase in redundancy of

design through the standardization of manufacturing steps and organizational standardization.

He also cites the fact that even where there was little division of labor, it was beneficial for those who had the capital to invest to install a number of looms in one building to better supervise their workers -
redundancy of regulation:

The best known of these manufactory-capitalists is John Winchcomb, popularly known as Jack of Newbury, who, being the son of a draper and apprenticed to a rich clothier, was farsighted enough to marry his master's widow. If the descriptions of him are true, he employed several hundred weavers, and owned a dye-house and fulling-mill as well. (Dobb, 1963, p.138)

The production of a product had been considered part and parcel of the activities of the social unit. The mastercraftsman had overseen this production as part of his expression of himself. It was not distinct from his role in the social unit. Here, in one generation, there is a shift in the way in which tasks related to production were perceived - from part of the activities of a family they shift to distinct money making activities done by replaceable laborers rather than by members of the household circle. The overseeing of the production of goods had become standardized, specialized and professionalized.

Thus, at the **supersystem level**, it is seen that economic growth is no longer the same in all settings. This supports the model presented in the previous chapter.

At the **system level** economic growth occurs where the model would predict - in settings with high information access - Holland and England. Stagnation and decline occurs in settings with low information access - Spain, Portugal, and Italy - and in settings with intermediate access - France - intermediate growth occurs.

At the **individual level** there are standard, specialized tasks and procedures being monitored by craftsmen who have become professional business owners. Tasks related to production of goods, which had been considered part of the activities of crafts people as intrinsic to their social identity become separated from the social role.

Additionally Holland, the first "free press" setting has become conservative because the "old out group" - the merchants and traders - have become the "new elite". Thus, they fail to support manufacturing innovation although members of Holland's "out group" continue to innovate.

Putting it Together

Because of the constraints of presentation the relationship between first and second phase development has been presented here as if they were separate and non-contingent. It is now time to put the relationships back together.

First phase development is important to the success of second phase development although it does not "cause" it.

The centralizing tendency and bureaucratization of the royal court creates infrastructure in the form of roads, standardized laws, regulations and courts. This helps the "out group" by facilitating the forming of connections throughout the country.

During first phase development there is an increased demand for luxury goods because more of the elite have more money. This creates a class of wealthy producers and traders of these goods. They in turn have desires for better goods which sets up a demand for middle quality goods. This in turn employees crafts people who then have more money and require low cost goods. This is the 17th century version of "trickle down benefits". However, the demand moves economic growth around

geographically as each country in turn finds its niche and becomes conservative (see above and Steensgaard, 1978).

Italy, the seat of the Church and therefore the country with the best information access, started the age of exploration and the Renaissance stimulating innovation in navigation and learning. The press is invented. Spain used the innovations in navigation, published in some of the earliest books, and maps, improved by the corrective feedback loop made possible by the press, and colonized the New World bringing in great wealth. Holland sold luxury goods to Spain. England sold quality cheap goods to Holland. This accounts for the eventual dominance of England. England entered the "innovation race" late and was able to benefit from a healthy lower class market in Holland. England was able to take advantage of the broad based market at greatly reduced cost because of the innovations in the organization of the production process as well as innovation in product - Trickle up wealth.

The two phases of development which are apparent from the supersystem level, are not distinct in the experience of the individuals at the system level. During the explorations of the 15th century and expansion of the sixteenth, people in the Protestant countries are experimenting with all kinds of innovations and organizational forms. Braudel (1984) makes the point that

there were many attempts to rationalize production and to organize workers in a single building but that many of these failed. This was partially due to infrastructure problems and partially the nature of learning - trial and error.

The two phases of development are partially real and partially an artifact of historical observation. Real in that there certainly was a phase of elite centralization, bureaucratization and absolutism which led to explosive growth which terminated in a downturn of some sort. And an artifact of observation in that activities which we see as relating to second phase growth have been developing throughout the first phase period and only become apparent to history after the flash and glitter of the activities of the royal courts has subsided.

Both the failed experiments of merchants and manufacturers and the sons of peasants and craftsmen who learned to read are invisible to history. It is not until those sons have grown, innovated and become wealthy and their innovations successful that history can see them. By then they do not seem to be part of the "out group" they seem like members of an elite, even if it is a new elite.

This is why there is a tendency to discount the impact of information technologies. For example, it makes sense that perhaps 1% or 2% of a literate population will

be innovative, and that 0.5% of those innovations will be successful, and that therefore the larger the number of literate people the larger number of innovations there will be. But the feedback loops are so long and the connection so tenuous that the relationship is not obvious.

As this examination of history moves forward to the electric information technologies the feed back loops become shorter but the contrasts also become less sharp as greater complexity from greater connectivity clouds the picture.

Chapter VII

THE ELECTRIC INFORMATION REVOLUTION

THE TELEGRAPH AND TELEPHONE

Note on the Presentation of the Chapter

The major purpose of this work has been to develop a model of information technology impact. The press has been the major technology examined. Before concluding, I suggest a brief glance at the beginning of electric information technology - the telegraph and telephone - and the revolution in organizational form which followed it. Because of constraints of time, space and energy, this will be more of an indicator of directions for future research than an extensive analysis.

Introduction

In the years between the invention of the press and the invention of the telegraph in 1837, there was expansion of production due to advances in science and technology,

but there was no change in how people organized themselves to do the tasks related to production, nor was there any new way of thinking about organization. Chandler writes:

If the expansion of the economy brought specialization in the activities of business enterprise, it did little to alter the internal operation of the organization of these enterprises or their methods of transacting business. American businessmen still relied entirely on commercial practices and procedures invented and perfected centuries earlier by British, Dutch, and Italian merchants.. Traditional forms were refined, but...not fundamentally altered (Chandler, 1977, p.16).

Of the change in organizational form which occurred at the close of the last century and the beginning of this century he says:

Those institutional changes which helped create the managerial capitalism of the twentieth century were as significant and as revolutionary as those that accompanied the rise of commercial capitalism a half a millennium earlier (Chandler, 1977, p.16).

In these statements alone there is an analogy between the time period associated with the impact of the press and the time period associated with the telegraph and telephone.

The work in the previous chapter suggested that the rise of commercial capitalism was accompanied by, and was dependent on, changes in the organization of daily life. Therefore, it is necessary to be aware of the organization of the culture before the introduction of electric

information technology. Weibe writes about the culture of the time period:

America during the nineteenth century was a society of island communities. Weak communication severely restricted the interaction among these islands and dispersed the power to form opinion and enact public policy. Education, both formal and informal, inhibited specialization and discouraged the accumulation of knowledge. The heart of American democracy was local autonomy...Almost all of a community's affairs were still arranged informally. (Weibe, 1988, p. xiii).

Of the major cultural and social changes during the early twentieth century Weibe says:

By contrast to the personal, informal ways of the community, the new scheme was derived from the regulative, hierarchical needs of urban-industrial life. Through rules with impersonal sanctions, it sought continuity and predictably in a world of endless change. It assigned far greater power to government... and it encouraged the centralization of authority. Men were now separated more by skill and occupation than by community; they identified themselves more by their tasks in an urban-industrial society than by their reputations in a town or a city neighborhood..(Weibe, 1988, p. xiii)

Here again there is support for the model as things which had previously been dependent on the personal and social life of the community have become alienated - impersonal, based on notions of professionalism, economic relation and skill rather than social position, personality and community.

These shifts, from small, family owned, merchant capitalism to diversified, managerial capitalism and from small, personal communities to hierarchically organized, professionalized urban-industrial life and the impact of electronic information technology are the subject of this chapter.

Review of the Model

Let us review the implications of the model developed in the previous chapters in the examination of the press.

During first phase impact at the supersystem level, we should see rapid economic growth. At the system level, this should be essentially the same in each setting. This economic growth should be based on innovation which allows expansion and elaboration of existing organizational structures by members of the elite resulting in an increase in connection. At the individual level, where there is information access, we should see increasing standardization, specialization and professionalization which is the result of the alienation of information. We should see things which had been tacitly considered intrinsic to the social individual become separated from the social role. First phase growth should terminate in a

recognizable downturn due to an overshoot of the limit for that form of organization.

During second phase impact at the supersystem level, we should begin to see the effect of differential information access in different settings. At the system level in settings where there is high information access, we should see economic growth associated with new innovation. In settings with low information access, we should see economic stagnation and decline. In settings with intermediate, information access we should see an intermediate condition. At the individual level, where there is information access, we should see increasing standardization, specialization and professionalization which is the result of the alienation of information. We should see things which had been tacitly considered intrinsic to the social individual become separated from the social role.

Over all, we should find that the settings which experienced economic growth due to innovation first will become conservative first because success tends to decrease innovation.

In short, wherever there is access to information (amongst the elite of all countries and amongst all classes where information access is not controlled), we should be able to observe the local effect of centralization,

standardization, specialization, communication and control. The greatest wealth should be observed in global settings which have the least centralized control of information because they allow the most access.

Overview - Pro and Con

Pro

Supersystem level: The prediction that the setting with the most information access in terms of information machines per capita is supported for this technology. The United States developed both the telegraph and the telephone, and has always been in the forefront of adoption, use and development. People in the U.S. have been the first to make them part of the culture. (Dilts, 1941; Brooks, 1976; Perry, 1977; Attali & Stourdze, 1977; Cherry, 1977; Pierce, 1977). The economic world leadership shifted from Great Britain to the United States because of changes in the organization of the economy related to speed of communication, distribution and production.

System level: Attali and Stourdze write about the failure of France to adopt and use the telegraph and the telephone as an interactive medium and tie this to economic

failure. They see 1880 as the turning point before which Britain and France were the most developed capitalistic nations. Competition from nations with more advanced communications provoked a crisis in the 1880s. They write:

During that period of critical changes in capitalistic production, the U.S.A. developed its own power structure, banking system, and telecommunications network at home and abroad. A new strategy of growth appeared: in times of expansion, foreign markets were increasingly exploited not only as consumers but also in part as sources of production with very fast channels of distribution and sale, resulting in much more competitive management (Attali & Stourdze, 1977, p. 109)

This new competitive form of management was initially developed by railroad managers using the telegraph to control personnel, relationships and machinery (Chandler, 1977). The development of managerial capitalism is based on communications and has given the United States its competitive edge. Attali and Stourdze write:

The growth of enterprises needing world markets made them more difficult to manage: the chain of production became unwieldy, requiring more time and space. To remain competitive, time lags in distribution had to be kept brief. The long technical processes of production and distribution had to be mastered, something that the local power structures (in France) unfamiliar with the workings of big industrial firms could not grasp. From then on, the telephone acquired vital importance. It helped bring the 1880 crisis to an end by winning new markets, and it played its part in the rampant competition in national and international markets until the 1929 depression. (Attali and Stourdze, 1977, p.109-110)

Individual level: The Weibe quote above and the fact that managerial hierarchies were run by new information technologies by professional managers support the model. The essence of managerial capitalism is the association of power and authority with competence rather than with birth or ownership. In other words, the alienation of information associated with managing a particular portion of the organization was disassociated from the person of the owner as a social individual.

Con

One difficulty in applying the model to the telephone and telegraph is there is no clear cut boundary between first and second phase behavior. There were economic downturns and depressions which followed periods of expansion and simultaneous growth, but there were several of them during the time period - 1870, 1885, 1896, 1921 and 1929. Also, several different technologies, the railroad*, the telegraph and the telephone must be considered.

Mapping first phase and second phase impacts as in figure 28 suggests that, except for the first depression of 1870 and the last - the great crash of 1929, the economic downturns associated with one technology occur during

* Note: It vastly increased the speed of mail communication, e.g. letters could be transported city-to-city in three hours, not three days. Transportation effects are also simultaneous and increase connectance in the economic system.

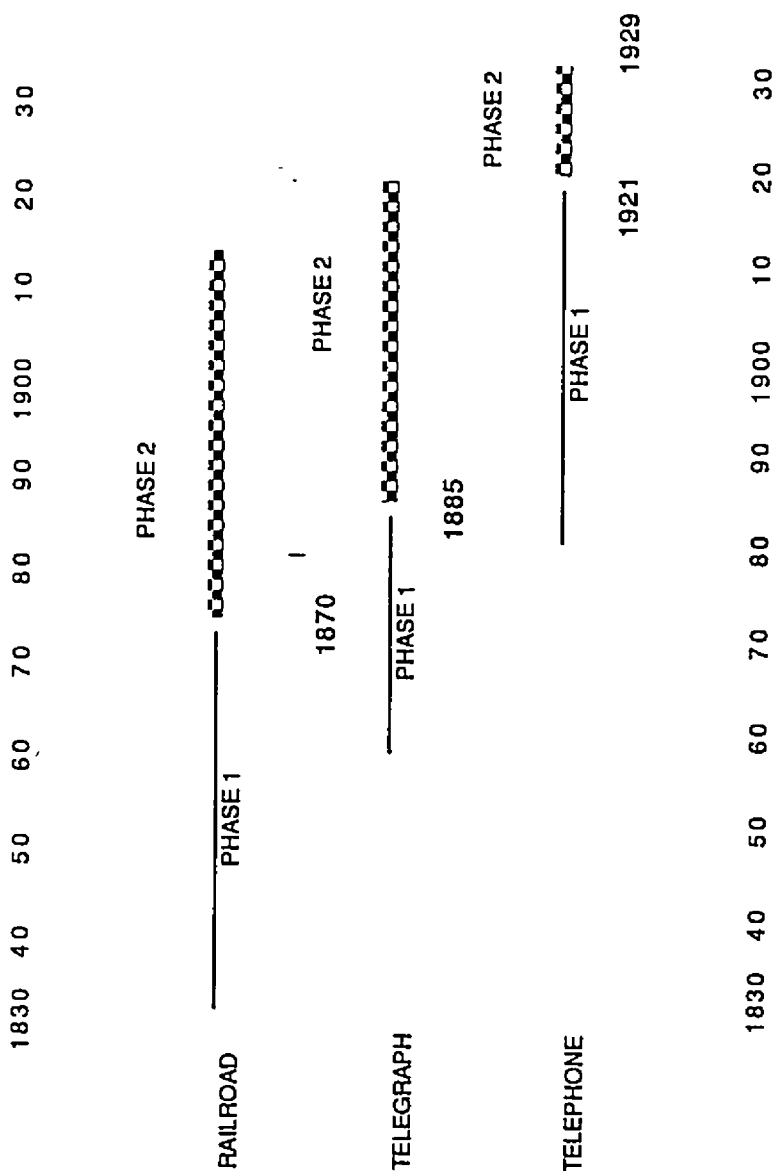

Figure 28: Time line, information technology impacts and economic downturns: Instances of economic instability mapped against the overlap of information and transportation impacts.

The growth phase of another technology. From this it is possible to predict that the depressions of 1885, 1896 and 1921 were less severe, because of the overlap of growth due to one technology occurring at the same time as a downturn at the end of phase one of another technology. It is generally agreed that the depression of the 1870's was the nation's longest depression and that it was due to the overexpansion and overinvestment in railroads (Weibe, 1967; Chandler, 1977), and the Great Depression of 1929 followed the largest single expansion of phone service (Dilts, 1941; Brooks, 1976) at a time when the managerial revolution was essentially complete (Chandler, 1977; Weibe, 1967; Galambos & Pratt, 1988).

Another problem is the difficulty in identifying the elite who benefited first from the introduction of information technology. It is possible to say that the elite were the businessmen of England, Europe and America who were able to expand their businesses at the end of the nineteenth century because of the information revolution including the railroad, or that the railroad barons who benefited first from the telegraph and telephone were members of the elite. This may indicate that the model is wrong in so far as it focuses attention on the elite.

I suggest that "unpacking" the dynamics associated with information technology and the elite shows: 1) the

individuals who have first access to the benefits of the information technology; 2) those who are able to control the spread of information technology; and 3) the building of infrastructure which is necessary to economic development but is not sufficient to cause development.

More closely examining the electric information technologies may clarify the role of first phase impact on economic development.

Focus - Zoom Out

Going back to the original purpose of this work to gain a focus for further investigation shows that although the boom and bust, economic impact of the various technologies are difficult to disentangle, the major purpose of this work is to understand cultural and organizational change based on changes in perception due to changes in information access. From this perspective, the distinctions between the different technologies becomes less important. What was occurring during the time period, from the perspective of individuals in the society, was a continuing decrease of geographical constraint due to a continuing increase in the speed of communication and transportation.

This conceptual zooming out or stepping back allows new patterns to emerge. There are three periods of interest to the revolution in organizational form: 1) the growth of the railroad before the telegraph, when there was little or no organizational change and the difficulties inherent in managing a large organization are apparent; 2) the period of entrepreneurial firm when middle management became disassociated from ownership; and 3) the emergence of managerial hierarchies when management and ownership was completely disassociated and the revolution in organization was complete. Thus, the organizational changes occur into two phases: 1) the entrepreneurial firm, and 2) managerial hierarchies. These may be equivalent to first and second phase impacts in the model.

Focus - Zoom in - Before Organizational Change

Examining the period before organizational change allows us to see the effect of the constraint of insufficient channel capacity to monitor the increasing connections in the system.

Before railroads could successfully run and impact the economy, the problems of control of men and machines had to be solved. There were terrible accidents

due to scheduling problems. Time had to be standardized so that the time in one town was the same in another town, otherwise trains would not meet when expected and would crash (Kirkland, 1961; Chandler, 1977). The coordination of the movement of trains had to be kept simple.

For example, on the busy forty-four mile Boston & Worcester Railroad, passenger trains left each terminal at precisely the same time - 6:00 A.M., 12:00 noon, and 4:00 P.M. One daily freight departed immediately after the morning passenger train. The trains would meet at the mid-point, Framingham. Neither train would move on to its destination until the other had pulled into the station (Chandler, 1977, p.96)

The problems in management were equally limiting. Cochran quotes financier John Murry Forbes of Boston, "While there are a hundred good projects, you will find it hard to choose ten men to manage them." (Cochran, 1981, p.125).

Management practices of the times were not adequate to oversee an organization as large as any railroad. Most management was based on the personal qualities of the owner, and supervision based on a few "number-one workmen". Even the more elaborate structure of the textile mill, where there was a recognizable hierarchy, it consisted of only a carder, spinning room overseer, throstle room

overseer, boss weaver and overseer of looms under a general supervisor.

There was little or no change in organizational form during this time period. Further, despite the increase in speed and efficiency of transportation, the growth of railroads before 1840 was slow and the economic impact was primarily the direct impact of capitalization and purchase of material for the road itself. There was little second order impact and the economic effect was not dramatic (Chandler, 1977; Cochran, 1981; Weibe, 1967).

According to Cochran:

Although the 1830s was a decade of more railroad building in the United States than in Britain, only at its end were Baltimore, Philadelphia, and New York connected by rail, and one had to wait another decade to go by train from Boston to Washington or from New York City up the Hudson River. Consequently, except for the immediate Boston and Philadelphia areas, the effects of the railroads in these first decade of building were greater in the demand for equipment than in reorganizing the shipment of goods. (Cochran, 1981, p. 103)

Chandler writes that, as railroads became larger the inadequacies of traditional personal methods of management became more and more obvious. The Western Railroad connecting Worcester, Mass, and Albany, New York, became the first interregional railroad. It ran three trains a day over 150 miles on a single track without the benefit of telegraph signals. Trains met three times a day and the

Western, predictably, suffered a series of serious accidents including a head-on collision on October 5, 1841 which killed a conductor and a passenger and injured others. This, predictably, caused a public outcry which brought to the fire the problems of managing large organizations.

(Chandler, 1977, p.96)

I suggest that the economy was kept from growing because it did not have the organizational structure or the communications capability to monitor the connections that its technology made possible - it had reached the limit of its variety.

The Beginning of Organizational Change: 1840 - 1880

The crash of trains on the Western Railroad alienated the problems of management of complex organizations. The solution, a "Report on Avoiding Collisions and Governing the Employees" was the first attempt to define internal organizational structure. It attempted to define responsibilities, authority and communication for the road's administration, maintenance and operation. Chandler reports:

This embryonic modern business enterprise included two middle managers - the master of transportation and the master mechanic - and two top managers - the

superintendent and the president. The latter, who became in 1852 a full-time officer, was the link between the full-time salaried managers and the part-time representatives of the owners elected to the board of directors. (Chandler, 1977, p.98)

The adoption of the telegraph and the managerial structure outlined in this report was adopted by all long lines and made rail travel relatively safe. As the volume of traffic increased through the 1850s, the railroads outgrew this structure. They began to find that an increase in size lead to an increase rather than a reduction in per mile operating costs. Chandler quotes Daniel C. McCallum, general superintendent of the New York and Erie:

A Superintendent of a road fifty miles in length can give its business his personal attention, and may be constantly on the line engaged in the direction of its details; each employee is familiarly known to him, and all questions in relation to its business are at once presented and acted upon; and any system, however imperfect, may under such circumstances prove comparatively successful. (Chandler, 1977, p.96)

Here McCallum is describing personalized, social managerial methods. For longer roads he states:

In the government of a road five hundred miles in length a very different state exists. Any system which might be applicable to the business and extent of a short road, would be found entirely inadequate to the wants of a long one; and I am fully convinced that in the want of system perfect in its details, properly adapted and vigilantly enforced, lies the true secret of their [large roads] failure; and that this disparity of cost per mile in operating long and short roads, is not produced by a difference in length, but

is in proportion to the perfection of the system adopted. (Chandler, 1977, p.98)

McCallum contributed to the "perfection of the system" by his enuciation of "general principles" of administration:

- 1) A proper division of responsibilities.
- 2) Sufficient power conferred to enable the same to be fully carried out, that such responsibilities may be real in their character (that is, authority to be commensurate with responsibility).
- 3) The means of knowing whether such responsibilities are faithfully executed.
- 4) Great promptness in the report of all derelictions of duty, that evils may be at once corrected.
- 5) Such information, to be obtained through a system of daily reports and checks, that will not embarrass principle officers nor lessen their influence with their subordinates.
- 6) The adoption of a system, as a whole, which will not only enable the General Superintendent to detect errors immediately, but will also point out the delinquent (McCallum in Chandler, 1977, p. 102)

On first reading this may seem harsh, but it was a first attempt at linking responsibility and power. For example, McCallum gave the right to hire and fire to those in charge of the operation of the division. This was a new concept in management. Before this, only the owners or their direct representatives had power. In addition, McCallum's principles constrained power associated with

notions of class because it stressed that subordinates were accountable to "*their immediate superiors only*; as obedience cannot be enforced where the foreman in immediate charge is interfered with by a superior officer." (in Chandler, 1977) Previously power was held by individuals on the basis of their relation to the owner - class relations - rather than on the basis of their position - professional relations.

To make this clear McCallum drew up one of the first organizational charts of a business enterprise to illustrate the lines of communication and authority. He was able to put his principles into action by his revolutionary use of the telegraph. Chandler writes:

McCallum stressed that channels of authority and responsibility were also channels of communication. He paid close attention to improving the accuracy of information and the regularity and speed with which it flowed through these channels... McCallum's use of the telegraph brought universal praise from the railroad world both in this country and abroad. What impressed other railroad managers was that McCallum saw at once that the telegraph was more than merely a means to make train movements safe. It was a device to assure more effective coordination and evaluation of the operating units under his command (Chandler, 1977, p.103).

McCallum made use of the capabilities of information technology in the increased ability to communicate and model. His use of the notion of a dedicated channel of communication as an ongoing error

detector and his innovative use of the telegraph suggests that, for McCallum, communication had emerged from the background of daily life as a separate and important activity. The model would suggest that the new perception of communication allowed the creation of the organizational chart and the beginnings of managerial hierarchy.

In addition, he understood the use of collecting statistics on all phases of operation so that operations could be improved. His work was extended by other railroad people who added innovations in accounting procedures and the notion of a division between line and staff personnel.

In Europe and on short lines in this country "natural management" continued to be used (Cochran, 1981) but for longer lines it was too costly. Chandler writes:

By the 1880s, however, the innovations of the 1850s and the 1860s had become standard operating procedures on all large American railroads. Expanding traffic and the growth and size of the roads forced the senior railroad managers to pay attention to their administrative and informational procedures. Moreover, as railroad managers became more professional, information about those methods became disseminated more systematically (Chandler, 1977. p.120).

This same organizational structure was adopted by communications organizations as they grew. The first telegraph companies, for the most part, were owned by railroads. As the telephone began to supplement the

telegraph, it adopted the same rationalized business structure. (Chandler, 1977; Hibbard, 1941; Cochran, 1981; Weibe, 1967).

The major innovation was the disassociation of class and ownership from authority and power. The notion that a conductor had the authority and the power to say to his superior that he would not hold the train was remarkably revolutionary. It began to establish professionalism as a determinant of social and individual success.

Despite this, the ultimate authority was still associated with ownership and upper managerial decisions were still made by the owners or their direct representatives. The move toward rationalized upper management occurred first in the communications industry. Galambos and Pratt (1988) write about the process of creating a centralized corporate combine:

In the fledgling telegraph industry of the 1840s, for instance, the interests holding the Morse patent had at first licensed a series of small enterprises to construct lines between some of the countries leading business centers - New York, Philadelphia, Boston, Buffalo, and St. Louis. When competition arose, it too initially took the form of a loosely united federation of entrepreneurial firms using local capital to build sections of an opposing telegraph network. But in the 1850s, these partnerships yielded to a corporate form of organization, and a series of mergers made the Western Union Company the dominant firm in the industry. By 1899, Western Union had absorbed all its major competitors and was the largest firm doing business in the country .

In this style of centralized combine the various functions performed by the owner of an entrepreneurial firm were divided up among specialists (Galambos & Pratt, 1988, p.30).

The information gathered by these specialists became the basis for corporate decision making and would eventually disassociate the day to day decision making from ownership. But, at this time, in most of the business world, the entrepreneurial firm was the dominant business form.

The entrepreneurial firm was run by an individual owner, innovator, or a small group in partnership who made all the decisions and directed the managers under him. As the firm grew, it might rationalize middle management but the firm revolved around the owner. The entrepreneurial firm was and is still a flexible form in which innovations can swiftly be put into practice. General Electric, Bell Telephone, Swift, Aetna, Weyerhaeuser, Ford and today's Apple computer are well known examples of corporations which began as entrepreneurial firms and then grew into corporations which were managed completely by professionals. Galambos and Pratt write of the entrepreneurial firm in America of the 1840s and 1850s:

In this setting the owner-innovator was an active participant in a congenial political system, the master of his labor force and technology, the main agent in obtaining capital and credit, and the primary factor in buying the firm's supplies and marketing its

products or services. In many cases the markets were local or regional, but aided improvements in transportation and communications were beginning to break down barriers to interregional trade... The distribution network was an intricate web of wholesalers and retailers, each of whom had little control over the prices they paid or received. Businessmen set their prices at the level dictated by the market; they were in essence "price takers" in a market system that resembled the neat models of theoretical economics (Galambos & Pratt, 1988, p.23).

The innovative nature of the entrepreneurial firm allowed it to quickly innovate to take advantage of new technology, communications and transportation. This flexibility and growth potential made the years following the Civil War years of economic expansion.

From the late 1860s through 1893, the American economy grew at an unusually high rate. Heavy investments in railroad construction were a prominent feature of the phase of growth, but what was most unusual was the breadth of the development and the multitude of economic opportunities it created. (Galambos and Pratt, 1988, p.27).

In America during this period, there was economic growth based on innovation in all types of business, but innovation in business organization was limited to the rail and communications industries.

The rest of the business sector was innovating in other areas: science, technology, marketing, and creating new products and taking advantage of the increasing efficiency and speed in transportation and communication. In Europe, there was innovation in technology and science but

little change in organizational form - the persistence of "natural management".

In terms of the model, there was already a difference in the different settings on a supersystem level: American railroads adopting managerial hierarchies and European railroads keeping "natural management", but all settings were experiencing economic expansion. This examination of the time period also suggests that the important variable in the discussion of the elite was their access to information technology. This implies that the essential difference between first and second phase behavior is the depth of penetration of increased information access rather than the existence of an elite *per se*.

The Growth of Managerial Hierarchies - 1880 - 1920

During the second phase, the organizational revolution spread out of the transportation and communications sector. Businesses of all sorts began to organize themselves into hierarchies. They were able to do this because they could take advantage of the new connections to markets and resources made possible by the railroad, and they could monitor those connections through

use of the new communications technologies - the telegraph and, increasingly, the telephone.

The telephone eliminated the need for a specialist to operate it. It made geographically independent interactive communications available to everyone.

Initially, it was marketers who took advantage of the speed of transportation and the new forms of communication. Chandler writes:

Then in the 1870s and 1880s the modern mass retailer - the department store, the mail-order house, and the chain store - started to make inroads on the wholesaler's markets.

All these mass marketing enterprises had the same internal administrative structure. Their buying and selling organizations, by using the railroads, the telegraph, the steamship, and improved postal services, coordinated the flow of agricultural crops and finished goods from a great number of individual producers to an even larger number of individual customers. By means of such administrative coordination, the new mass marketers reduced the number of transactions involved in the flow of goods, increased the speed and regularity of that flow, and so lowered costs and improved the productivity of the American distribution system (Chandler, 1977, p.209).

Organizational change in production was slower than in mass distribution:

The revolution in production came more slowly than did the revolution in distribution, for it required further technological as well as organizational innovation. The new methods of transportation and communication, by permitting a large and steady flow of raw materials into and finished products out of a factory, made possible unprecedented levels of production. The realization of this potential required, however, the invention of new machinery and processes. Once these were developed, manufacturers

were able to place within a single establishment (that is, to internalize) several processes of production (Chandler, 1977, p.240).

The lag in the change in organizational structure in the processes of production should not obscure the fact that in both mass distribution and mass production the organizational change was the same. And, it was the same change which had occurred in the transportation and communication industries for the same reason. The combination had the effect of not only increasing the number of connections in the system, but increasing the amount of "stuff" flowing through each connection.

This increase in the volume of output produced daily by a processing unit and in the number of transactions handled daily by a distributing unit permitted business enterprises to subdivide their activities into several operating departments. Of even more significance, the new velocity of output flow encouraged the integration of several units into a single enterprise. The managers of these new multiunit enterprises were able to monitor the processes of production and distribution and to coordinate the high speed, high volume flows through them more efficiently than if the monitoring and coordination had been left to market mechanisms (Chandler, 1977, p.208).

The integration of these two processes - mass production and mass distribution - completes the process of transition from the small, personal organization to the modern, industrial corporation we know today. Some corporations developed their own units to complete vertical

integration and some merged or acquired units which allowed them to control all the processes necessary to the production and distribution of their product. But regardless of how they come to the process, only those who created a professionalized management hierarchy succeeded.

The second phase of the revolution in organizational form was based on vertical integration. This did for upper management what large size and the need to control many units had done for middle management.

As businesses merged and created new units that were the size of entire businesses, it became apparent that the decision making process would have to be based on something other than personal hunches and flair. This made the owner and innovator obsolete. As Schumpeter (1950) suggested, the qualities of a good entrepreneur are not necessarily the qualities of a good corporate manager. In addition, where the vertical integration was the result of merger the old owner and innovator was often the head of a division. This ultimately led to clashes in policy which had to be settled. Successful corporations rationalized so that the ultimate authority was based on the soundness of the decision in financial terms, based on evidence collected and manipulated by business specialists.

At the beginning of the twentieth century the power of the owners became limited to a veto. This was true even

where members of the entrepreneurial family continued to hold a substantial share of the stock. Chandler writes:

Nevertheless, members of the entrepreneurial family rarely became active in top management unless they themselves were trained as professional managers. Since the profits of the family enterprise usually assured them of a large personal income they had little financial incentive to spend years working up the managerial ladder (Chandler, 1977, p.491).

The managerial revolution was complete. Decision making power and authority to take action on those decisions had become rationalized - based on scientific reasoning and standardized methods using evidence collected through improved communications channels. Chandler says:

The visible hand of managerial direction had replaced the invisible hand of market forces in coordinating the flow of goods from the suppliers of raw and semifinished materials to the retailer and ultimate consumer. The internalizing of these activities and the transactions between them reduced transactions and information costs. More important, a firm was able to coordinate supply more closely with demand, to use its working force and capital equipment more intensively, and thus to lower its unit costs. Finally, the resulting high volume throughput and high stock-turn generated a cash flow that reduced the costs of both working and fixed capital...By 1917 the integrated industrial enterprise had become the most powerful institution in American business and, indeed, in the entire American economy. By then too, leading American industries and the economy as a whole had taken on their modern form (Chandler, 1977, p.286).

The Notion of the Elite Revisited

Above, we noted that it was difficult to pick out the neatly parsed phase behavior we saw with the press, and we did not see an elite class benefiting first from the introduction of information technology. Based on the last two sections of the chapter, I would suggest that the important thing about the elite is not the membership in a class but their access to information technology. The railroads had first access and were the first to establish new organizational forms based on the notion of dedicated communication channels. The change in organizational form in the railroads defines the first phase of organizational change.

In addition, the telegraph itself seems to emerge as an elite form of the technology - it required specialized knowledge and was operated by specialists. This is analogous to the position of literacy before the introduction of the press. Members of the church controlled information access and were the source of learning. The press popularized literacy and brought information access to common people in the same way that the phone brought interactive, instantaneous, geographically independent, communications to the common

people. Thus the notion of the elite is the notion of limited access rather than class.

Why the United States?

The model has predicted correctly that economic development would be greatest in the United States because it was the setting where there was the greatest information access. However, there had not been any Inquisition in Britain or France which controlled the adoption of the telegraph and telephone. In 1840, France and especially Great Britain led the world in industrial development. Our model has proposed that success is conservative. Perry writes of the early days of the telephone in Great Britain:

The telephone was considered a luxury by some because great Britain already possessed the finest communications system in the world. Rowland Hill's successful campaign for a Penny Post had marked a turning point in the 1830s, and the nationalization of the telegraph industry had further added to the strength of the Post Office (Perry, 1977, p.75).

The attitude of many is captured by this statement by the chief engineer of the British Postal Service, Sir William Preece:

I fancy the descriptions we get of its use in America are a little exaggerated, though there are conditions in America which necessitate the use of such instruments more than here. Here we have a superabundance of messengers, errand boys and things of that kind..The absence of servants has completed

Americans to adopt communication systems for domestic purposes. Few have worked at the telephone much more than I have. I have one in my office, but more for show. If I want to send a message - I use a sounder or employ a boy to take it (in Pool, et al., 1977, p.128).

In France, we finally find control of communications by an existing elite. Attali and Stourdze attribute the failure of French society to adopt the telephone to the way communication was perceived by the state. They write of the formation of the General Telephone Company in 1881:

It was the beginning of a unique chapter in the history of French communication because it introduced two-way dialogue into a domain that up to that point had been entirely conceived in terms of a one-way monologue. A society built on order and hierarchy - such was the French society in which the telephone appeared... Communication, as understood by the French centralized state, was primarily a lecture which the State, with professorial wisdom, delivered to society. (Attali & Stourdze, 1977, p.97)

Attali and Stourdze quote a bill proposed under Louis Philippe (1830-1848) which they feel states the basic position:

Governments have always kept to themselves the exclusive use of things which, if fallen into bad hands, could threaten public and private safety: poisons, explosives are given out only under State authority, and certainly the telegraph, in bad hands, could become a most dangerous weapon. Just imagine what could have happened if the passing success of the Lyons silk workers' insurrection had been known in all corners of the nation at once. (Attali & Stourdze, 1977, p.99)

The telephone as well as the telegraph suffered and French industrialists of the late nineteenth century were not given the tool they needed. Attali and Stourdze write:

Industrialists needed the telephone ... to create new means of communication that would have increased productivity, conquered foreign markets, speeded distribution, and restored profitability.

Unfortunately for France, the men who controlled public funds then were not interested in industrial expansion. On the other hand, the industrialists still had no say over the channeling of public expenditures. (Attali & Stourdze, 1977, p.110)

Here we see that the British and the French did not see any need for fast interactive communication. They were secure in their belief in their economic dominance. They saw the telephone as a disruption in the well ordered successful social and political equilibrium they enjoyed. In both countries, the telegraph and telephone was used to make railroads safe and to give orders in business and government but not to make businesses more successful. Eventually, they lost their economic dominance by continuing to believe in the methods and organizational forms which had brought them their economic success.

They were not alone in their feeling of threat. In America, the various populist movements, the anti-trust movement and eventually the move to reform were all based on people's fears of the new larger world they were beginning to perceive. Weibe talks about the

contradictions of America at the end of the nineteenth century.

By the early eighties publicists were savoring the word "nation" in this sense of a continent conquered and tamed. It was a term that above all connoted growth development and enterprise... An age never lent itself more readily to sweeping, uniform description: nationalization, industrialization, mechanization, urbanization.

Yet to almost all of the people who created them, these themes meant only dislocation and bewilderment... As men ranged farther and farther from their communities, they tried desperately to understand the larger world in terms of their small, familiar environment. They tried, in other words, to impose the known upon the unknown, to master an impersonal world through the customs of a personal society. They failed, usually without recognizing why; and that failure to comprehend a society they were helping to make contained the essence of the nation's story. (Weibe, 1967, p.11)

Throughout we have used the word alienation to mean the process whereby something that was tacit becomes explicit - that some quality or something known as intrinsic to a person as a social individual becomes specified and examinable as if it were distinct from the person of the knower. We have also presented the word as if it were a "good," since it leads to economic development and to social change. Here we see another aspect of the process in the growth of an impersonal society which based its valuation on "objective" criteria rather than on personal or social (class) criteria.

The "Know nothings", the Granger movement and the populists were a reaction against the breakdown of their small personal world and an attempt to return to it. The reform movement of the early 20th century was an attempt to educate, heal, and control the new society and homogenize the people who were somehow different from the people one had always known.

The lives of women and children also changed as cities grew up into skyscrapers made possible by the telephone and the elevator and the suburbs grew out (Pool, et al., 1977, p.127). Women became more isolated and more economically marginalized.

Over time more goods were manufactured and more people had disposable income. Markets expanded and so did the size and diversity of the economic sector, the sector associated with and run by men. Women and children participated as underlings. They worked in sweat shops and mills as more and more of what a family wanted was to be had for cash rather than made at home. Still, until recently, most women had important economic roles and many had an independent source of income.

To keep the business sector expanding, it was important that women buy manufactured clothes and factory preserved foods rather than doing the work themselves.

This positive feedback loop emphasized man as bread winner and deemphasized woman as bread maker (figure 29).

One of the pumps which kept this feedback loop moving was advertising. Advertising may not have sold individual products well, but it did a great job of selling the American Dream. It gave people a criteria for happiness and told them it could be achieved with money.

We saw in the last chapter that the definition of women changed with the press. The electronic information revolution completed what the press started. Now the real world is the economic world. The definition of the family has changed. Women used to produce everything from thatched roofs to beer now only produce sex and children.

The entire definition of gender has changed and along with it the way we define individuals. We now define people by their occupation not by their social position or their family - we say I am a doctor or an engineer. We define our existence in terms of our relation to money not of our relation to each other.

The press redefined the basis for success, as money not social position, and the electric communications revolution redefined the notion of the individual by associating it with profession or occupation. In the next chapter we will conclude and attempt to understand where the next information revolution is taking us.

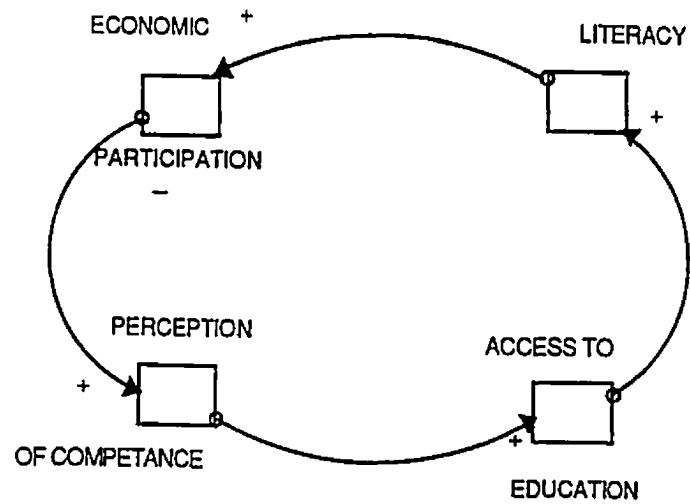

Figure 29: Impact of literacy and economic participation for men and women, positive feedback.

Chapter VIII

CONCLUSION

INFORMATION REVOLUTIONS AND CULTURAL CHANGE

Overview

I started this work explaining economic development and change in terms of information and information access. I ended the last chapter with a discussion of how the individual is defined and valued. This seems like a strange thing until we realize that the notion of economics is a realm which has been defined as distinct from the rest of life and that the defining has been done because of the way in which relations to information and decision making has evolved. This has purported to be a study of the world - out there - and how it changes, and yet it is ending up to be a study of how we perceive the world and how we change.

I have suggested that information access has played a major role in determining how cultures change. It has

impacted the size of the natural unit which has gone from no more than 15 or 20 individuals in the hunting/gathering band to the millions of people in a modern nation like the United States. And this relates to the creation of wealth.

The use of a model has helped in the thinking about the complexity of culture change. I have brought forth evidence which supports and tunes the model to make it more accurate, and have found that the model does indeed predict appropriately.

The model talks about information technology and we know that information technology increases our ability to model. This has been true for every information technology. Hunter/gatherers model the world through names and all things and all people are understood by their names. The invention of writing allowed people to count and model the world through numbers. Counting refined the notion of inclusion in a class by numbering - numbers of kinds of things - inventory, and numbers of kinds of people - census. Double entry book keeping spread by the printing press allowed the processes related to production to be modeled - it extended the notion of counting in the creation of economics. Value became associated with economic activity. The telegraph and telephone gave rise to a way to model communications relations in terms of channel and information flow. This associated authority

with professional position, and value became associated with competency, professionalism and what was known.

I have suggested that the introduction of a new information technology changes the way people think by alienating some activity which had been done tacitly so that the activity stands apart from the person. Speaking allowed the notion of distinction between persons (Mary is distinct from Sally) to emerge and the notion of relationship (Mary is the mother of Sally) in the notion of naming. Writing allowed the notion of quantity to emerge (20 bushels of wheat, 140 peasants, 15 priests). Printing allowed the notion of valuing the processes related to production to emerge from the background of the activities of daily life. Electric communications allowed the notion of communication to emerge as distinct from activities related to ownership.

Once an activity has been alienated, people can think about it and improve it. This has the result of increasing the redundancy of some aspects of the organization of life and decreasing the redundancy of others. This changes what is kept stable and what is not. For example, the model would predict that the family would become less and less stable as a continuing social unit because it has gone from being the major unit of

production, the major social unit as well as the major reproductive unit, to being only a reproductive unit.

I have also suggested, in the examination of the impact of the press and electric telecommunications, that the perception of women and children changed. Children emerged as distinct from adults as adulthood became more and more associated with literacy and profession or labor. Women became more and more marginalized as they had less and less access to the means of production and more and more of their traditional activities became alienated and done in the economic sphere.

The way a new information technology impacts a culture is partially dependent on the existing structure. If the culture is being run by a successful hierarchy, then the technology extends the control and success of that hierarchy, but the technology does not lead to structural change in organization nor does it impact the ordinary people. This was true with the press in China and with telecommunications in England and France. If there is no hierarchy that can successfully control the spread of the technology, then it can spread to the ordinary people and they can introduce innovation in how they organize themselves to do tasks. We saw this in Europe, especially the Protestant countries where the press was not

controlled, and in the United States where there was no national control of telecommunications technology.

The interesting thing about the change in the structure of organizations is that the new structure extends the connectance of the organization and establishes a hierarchy of control. People have a tendency to associate an increase in hierarchy to a loss of autonomy but the new form of hierarchy that emerges with information technology makes more individuals more autonomous than they had been under old forms of control.

For example, under the craft form of production, a journeyman lived with the family of the master, he was not allowed to marry until he had attained mastery in his craft. Under the putting out form of organization of production, the journeymen lived on their own and were able to marry as they chose. Under the bureaucratic organizational form introduced with the telegraph, workers were subject only to their own manager and their job responsibilities defined a range of activities where they had power as well as responsibility (the conductor had the power to tell the president of the company that he had to get on board or be left,) whereas before rationalized organizational form, all workers were subject to all managers. So there is a larger hierarchy but control between nodes is more limited.

The allocation of goods and the apportioning of work has gotten progressively faster. The movement of goods has become more and more dependent on communications and less and less on social factors. In the pre-press economy, goods were made to order or slightly ahead of orders according to a sensed notion of need. Resources were allocated to a person because of their position in the social group not according to their labor contribution. Book keeping allowed the processes and materials related to making and selling of goods to be valued and modeled; this allowed allocation of resources through market mechanisms which were more efficient than social mechanisms. Telecommunications allowed the vertical integration of organizations. Where this occurred, it allowed planning based on projection of needs to take the place of market mechanisms in the allocation of goods.

Coincident with these changes there have been changes in the locus of power. Before writing, the locus of power was with the clan or family unit. Writing saw the emergence of political and religious institutions which controlled information and information access. The fall of Rome left the Church in control of information access and the locus of power. The press shifted the locus of power to the centralized nation state. The telegraph and the telephone began the shift of power to the business

organizations, especially major manufacturing organizations.

The model has suggested that there are conservative reactions to the increase in connection and changes associated with increased communication e.g. Spain's reaction to the press in the Inquisition. The "no nothings", the conservatism of the Granger movement, and isolationism of the end of the last century associated with the increase in connection due to the telegraph and railroad.

I have also suggested that in settings where that conservatism has been successful there is a slowing of development and eventual economic decline. This happened in Spain in association with the press and in France in association with the telephone. Where the conservative reaction has been unsuccessful, the conservatism has been followed by reform and recasting of traditional relations and perceptions to accommodate the new way of perceiving and relating. Parliamentary reform in England after the press (Trevor-Roper, 1967) and the social reform movement of the early twentieth century in the United States (Weibe, 1967).

Let me now go on and attempt to project the results to the current information technology revolution.

Computer Technology - Supersystem level

Starting an examination of computer technology with the introduction of mainframe computing, the major economic players of the time were the United States and the Soviet Union, with Europe and Japan as minor players. Two phases of computer technology can already be observed. The elite phase associated with mainframe computing and the second phase associated with PCs (personal computers). Mainframe computers were associated with big business and governments. Like writing in pre-press cultures and the telegraph, they were manipulated by specialists and used to increase the control of the physical processes and people within existing hierarchies.

The second phase technology - the personal computer is just beginning to have its impact on social and economic forms of organization. Nonetheless, on the supersystem level, the model can predict the economic success of the United States and the economic ruin of the Soviet Union based on information access. Currently, it would predict intermediate positions for the minor players because there are fewer personal computers per capita.

There should be a marked downturn of the economy as the expansion due to the initial savings in transactions costs come to an end. Organizations which have used

technology in a conservative way should be disadvantaged in relation to those which have used the technology in ways which restructure the organizational unit.

Computer Technology - System Level

On the system level in settings with high information access, there should be organizational changes based on the increased ability to model and to communicate. Computer technology has allowed criteria associated with decision making processes to be modeled. The various mathematical models which originated with mainframes and now with expert systems and artificial intelligence, are allowing decisions which were previously made by managers to be made by rote. The increase in the ability to communicate is apparent in E-mail and computer conferencing which allows communication to become time independent in the same way as the phone allowed it to become geographically independent. The increase in communications capability is also occurring in the control and monitoring of machines. This implies a flattening of the hierarchy from both ends. Production workers will become more involved with decision making and this may reduce management positions. This also opens up the possibility of organizations based on participative management.

Like the other information technologies, we would expect thinking based on the increased ability to model and communicate to push the boundary of the organizational structures prevalent in the economy. The press pushed production beyond the boundary of: 1) the family as the unit of production, to 2) the putting out system where one master monitored and benefited from the work of many workers, to 3) the manufacturing shop. The telephone allowed vertical integration of the organization which pushed the organizational boundaries out to include suppliers upstream and distributors downstream. Currently we are seeing tentative moves in the same direction as organizations experiment with JIT (just in time) inventory and TQM (total quality management), both of which imply a new way of thinking about notions of organizational boundaries.

This trend of pushing boundaries is due to a change in the pattern of redundancy. This changed the basis for the stability of a system from passive regulation to active regulation, like switching from insulation against cold to a thermostatically controlled furnace. Before JIT the stability of the supply system was assured by redundancy of material; with the introduction of new information capabilities organizations could assure the stability of their supply system through redundancy of communication.

Where these are successful they will make the organizations more efficient and will speed the allocation of goods. The ability to do this electronically may make the vertically integrated firm obsolete. The competitive advantage of the vertically integrated firm was that it was able to allocate goods more efficiently through planning than they could be allocated through market mechanisms. Eventually there should be an economy which is dominated by production units which have a vastly different geography than current production units. There should be better control of the processes of production but less control of the individuals involved in production. The new organizations should be more like the current information industry organizations and less like traditional manufacturing organizations. Increasingly workers should be able to be geographically independent as monitoring and control become computerized.

Over time, people have defined the responsibility of power differently. The Church was concerned for souls and did what little was done for social welfare. The absolutist state was concerned with military power and it built roads and ran the mail, and in England it administered the poor laws. The rationalized bureaucratic state which arose after the telegraph and telephone began to make itself responsible for education, health and safety

inspections, and social welfare. I would suggest that increasingly we will see business organizations taking over the role of being responsible for social welfare. This is already happening with pension and health plans and day care. Businesses will become more and more involved with education as they realize that an educational system designed to fill factories with obedient workers do not educate people for the computerized organization.

Computer Technology - Individual Level

Individual identity has emerged as distinct from identity defined by social relations through changes associated with information technology. Under the craft form of production, class relations determined what an individual did - if one was born into a carpenter's family, one was a carpenter or one married a carpenter. With the emergence of the sale of labor power under the capitalist form of production, labor was alienated - labor stood apart from the person as an individual. This made the individuality of the person more apparent because the person was not their labor and their economic welfare became associated with labor rather than with birth. With the emergence of rationalized business associated with the telegraph, the notion that, as a laborer, an individual had

power to act, brought the notion of the self into even clearer focus. People were perceived as capable and responsible individuals even if they were not part of the social group (family or class) that owned the organization. This also broke down notions associated with class and social group since economic welfare and social mobility are no longer necessarily associated with the ownership of the means of production.

On the individual level, what is being alienated by the computer - the ability to model decision making criteria - is beginning to impact the way we think about thinking. We are increasingly realizing that there are no right decisions, and there are no consistent ways of perceiving reality. We are coming to realize more and more that each of us lives within a private perceptual shell. As we became alienated from our labor through the rise of capitalism, we became alienated from our social group with the rise of the professionalized bureaucratic organization; we are now being alienated from our own thought processes.

As we are becoming alienated from our own thought process, we are simultaneously becoming able to create "virtual realities" through computer technology. This combination may well call all realities into question as we realize that we have been creating virtual realities all along.

Conclusion - Implications

In conclusion, the model seems to work. The model seems to allow us to predict. However, it is in this realm that it is also most disappointing. The same predictions could have been made with far less work.

Throughout the work, I have concentrated on what happens in settings where there is high information access. I have not considered the implications for settings where there is low information access other than to predict economic decline. The model can predict more than this.

In low information access settings, the model would predict that the processes of alienation of the individual from the social group would not have occurred. There would not have been an increase in education or in communication. At the same time, there would have been an economic depression. This means that people who identify strongly with their social group will experience a decline of the quality of life which is not associated with any change in behavior on their part. They would, therefore, be at a loss to understand why things they have done in the past which have been successful are not successful any longer. These two factors, little development of individual identity and worsening economic conditions, would create conditions where there is much distrust of those outside

the social group and a feeling that they somehow have been victimized.

To test this theory, it would be useful to look at the ethnic identities and attitudes of the people of various countries of Europe before World War I in the context of information access. If it was shown that there was a greater tendency to judge personal worth on the basis of ethnic group in low information access countries than in high information access countries, this could have profound implications for the current problems in the Third World and in Eastern Europe, where ethnic strife is causing massive instabilities.

Weakness and Incompleteness

The model has a number of weaknesses which perhaps can be better understood now that the work is substantially complete. Earlier in the work we defined success loosely according to the criteria of the economic person. This was related to the observation that, in settings which were in some respects successful, there was a tendency for a reduction in innovation. This explained Holland's lack of support for manufacturing interests and England's lack of interest in spreading phone usage. Now, with hindsight, we can suggest that the relationship between lack of

innovation and success is based on the ability of the existing social, economic and political power structure to control the spread of information technology. This control may be a deliberate suppression with the intent to maintain power as in the instance of Spain's control of the press or more recently Romania's control of the telephone. Or it may be innocent control as in the British business and political interests lack of enthusiasm and non-support of the telephone.

Recommendations and Wishes

What seems to be the operative consequence of this work is that if one has the power to control information technology it is in one's interest to do so, since new innovation is apt to create competitors. However, it is also true that in the long run if the entire setting is in a competitive supersystem then the economy will suffer as a whole, which will disadvantage individual organizations.

To use this work as a way to inform action, I would first want to determine the proposed time scale of the usage. If I were in a setting where the economic processes were moving very slowly, as in the early days of the press, then I might want to control information access because

information control is always a way to increase power and control - it is more lucrative to be a Spanish grandee than it is to be a Dutch merchant. However, if I were in in a world where the economic processes move very fast then information control still seems economically lucrative and is therefore very tempting, but the long run is much shorter and therefore the setting is more apt to become unstable. When the instability occurs, the organizational structures which have made the best use of the new technology will be more competitive. The more competitive organizational structures will develop in the organizations with less control of information access.

This leads me to suggest that the United States is in a good position because it is very information intensive, and many people have access to the current technology. However, it is also a very successful nation, and there are many people who feel it is in their interest to control information access. To the extent that the conservative faction in the nation succeed in controlling information access, the nation will not develop. To the extent that information access is increased, we increase our competitive position and economic development.

The current position of the Soviet Union supports the model. There has been no PC revolution there and they are in serious economic decline and associated instability.

The fact that that instability is associated with ethnic strife relates to the failure of the alienation of individual identity.

However, as the political organization of what was the Soviet Bloc sorts itself out, it will be important to know what the information policy is of the groups which emerge. We should also be aware of information access in the European Community and in Asia. To the extent that these groups succeed in giving their people information access, they will develop economically competitive organizations based on innovation. If one of these settings develops into a setting with higher information access than there is in the United States, then we will lose our economic lead.

The model suggests that to encourage development in the Third World, it is necessary to concentrate on things associated with high information access rather than on big ticket development projects. Much of the Third World is illiterate: few have good telephone networks much less personal computers linked through e-mail. This is reflected in the ethnic strife as well as in the economy. Funding information access development will increase the sense of the individual as an effective entity and break down the attachment to, and identification with the ethnic

group which is used by those who wish to control and to oppress.

Significance - Meta-Statement

The significance of the work is less in the conclusion or in the content than in the work itself as an example of a way to approach doing social science and history. The approach is meant as an offering to cyberneticians, historians and social scientists in the hopes of furthering the conversations in both fields. I take as basic that any offering which obscures or is designed to stop the conversation because it is "the last word" is not useful.

The conversations around cybernetics tend either to be that cyberneticians trivialize everything into "everything is connected to everything else," or that their model are so impossibly mathematical and abstruse that they are of little use to ordinary historians and social scientists. Thus, they tend to stop the conversation. I have pursued the work in hopes of demonstrating that it makes a difference how things are connected and that making those connections explicit allows clarity (not obfuscation)

into how society functions. Thus the work itself is a model for doing history and social science.

This leads us to a consideration of modeling. Modeling needs to be thought about from many different perspectives in relation to this piece of work.

Modeling for Doing

The method used in this work is an example of the way I would like to see social science operate. Although it does not look like the papers in natural science, it is based on my experience of how natural scientists do science.

For example, a person experiences the world; this makes her an observer. She thinks the world works in a general way. Some rough idea of theory or pattern guides the observations. Regularities begin to appear and the observer looks for similar instances in the work done by others. Some of the work done by others helps in the development of the pattern. Some of the work done by others illuminates the observer's own thought because it seems wrong. She finds that there are contradictions between what she thinks the patterns ought to be and the patterns identified by others. She begins to make a more careful observation of one time, instance, example, or

sample of how she thinks the patterns operate. This more careful observation allows her to formulate some formal notion of the phenomena she has been observing. Once the formal theory has been developed, the observer goes back to the phenomena and sees how well the theory describes the phenomena. She takes the theory and tries to see how well it fits other instances she believes are similar to her sample instance. This may show her gaps and inadequacies in the theory which she then tunes to reflect her experience with the new observations. Finally, the theory is used for prediction. Throughout the process there are notions, facts, and relations which are changed, tuned, added and discarded. Reflection on these also helps the scientist understand the problem.

The entire process is continually being iterated as the scientist goes from theory to observation to theory again. Thus, the conversation of science is re-enacted on a smaller scale in the thinking of the scientist herself. This circular interaction between observation and theory is the process which leads to construction of what we call knowledge.

The writing of papers in science takes the formalization or the theoretical abstraction of the phenomena, phrased in the form of an hypothesis, and tests it with replicable observations, and then either rejects

the hypothesis or lets it stand until there are further tests. In terms of this work, the first chapter would be theory (Chapter V) and the rest would only deal with the application of that theory. Much of what has been presented here is in the nature of walking the reader through the thinking as well as the distillation of the thinking in the presentation of theory.

Because the abstraction of theory is often mathematical and the observations are often formalized into counts or measures, there is a tendency to confound science with either the theory or the process of observation (methods). This creates a condition where individuals, wishing to do something scientifically, think that they have to "add mathematics" as either method or theory. This work is intended as a model for doing science starting from the premise that science is a process of interaction between careful observation of specifics and generalization of those observations into some form of abstraction.

Modeling of...

This work is a model of what I believe happened in certain timeframes. It is also a model of how I believe information and information technology impacts social systems. Part of that impact has to do with the

development of science and the development of how people perceive their world. This raises some interesting questions.

The model suggests that the information technology allows some things to be alienated while other things are not alienated. For example, the activities related to the processes of production were alienated by the ability to model them using double entry book keeping, whereas the activities related to raising children and running a household were not alienated. Regardless, the alienation of the production processes had a real effect on both the processes of production and the raising of children.

We have just alienated the dynamics related to cultural, economic and social development. The development of the model owes much to system dynamics thinking, which grows out of computer modeling. Thus, this work is a product of the processes that it is modeling. The consequences of what has been alienated will also affect those things which have not been alienated. However, since they have not been alienated, they are not perceived.

This raises questions as to the "truth" of the model. I think that models are neither true nor untrue; they are either useful or not useful. This raises the question, "Useful for what or whom?" This suggests that the act of modeling is both a political and a creative act,

not only an act of problem solving or prediction. That a model helps solve problems or provides a useful prediction does not imply any objective truth.

I suggest that modeling is political because what constitutes a good model is a choice of the conversations in that field. For example, if I talk about a model of an aircraft, the model will be different if I am talking to an engineer who specializes in jet engines, aerodynamics, or military logistics. It will be different again if I am talking to a twelve year old child who is building her first Sopwith camel. In each instance what is included and what is left out is dependent on the purpose of the model.

To a large extent, models in the social sciences and in history have been limited to statistical models of fairly constrained time periods, which predict a fairly narrow range of circumstances. I am suggesting, in this work, that large scale, non-mathematical, dynamic models are useful for looking at social systems, although they are neither true nor untrue.

The work done here talks about how the perception of the world changes depending on the model an individual has. And, it says that those models are dependent on the information technology of time. I am a person of this time, so computer models and modeling in general seems to be productive of some insight.

This indicates that over time history changes as the models we have change, according to our understanding of the larger world. If we live in a world where the major information technology allows us to name, we will think about history in terms of names or people, places, dates and things. If we live in a world where it makes sense to model in terms of numbers and statistics, we will see history in terms of things which can be counted like gross national product, deaths, births and life expectancy. We live in a world where dynamic models are beginning to be a reasonable way to see the world.

This work of history, like every work, is a creative history which presents a view based on the access of people to information and suggests that the understanding of experience is based on how our information technology permits us to model the world. Thus, we understand hunter/gatherers use of language as a way to model the distinction and the relationship between individuals and things. And, we perceive that their economy is based on social relations, and therefore their survival is based on their social system. Hunter/gatherers might say that we have a strange myth that certain pieces of paper or cards of plastic act for us as names which create social relations signified by gifts.

Neither of these is true or untrue. They are useful in so far as they further the conversation between people which will promote understanding. In our culture, models may promote understanding as naming does amongst hunter/gatherers to help us understand our relationship to the world. I have offered this particular naming in the hopes that it will be useful for understanding how things are connected, and as a warning that as we act in a way which deprives others of freedom of information access, so our economies, societies and cultures will ultimately be ruined. This indicates that our welfare, like the welfare of the hunter/gatherer is is intimately tied to the welfare of others but that we cannot impose or mandate their actions. We can only give them access to information and freedom to act upon it.

BIBLIOGRAPHY

- Abler, Ronald. 1977. The Telephone and the Evolution of the American Metropolitan System. In *The Social Impact of the Telephone*. Ed. Ithiel de Sola Pool. Cambridge, MA: MIT Press, 318-342.
- Abrams, Philip, and E. Anthony Wrigley, eds. 1978. *Towns in Societies : Essays in Economic History and Historical Sociology*. Cambridge, UK: Cambridge University Press.
- Allman, William F. 1989. The First Humans. *U.S. News and World Report* 106 (27 Feb):52-89.
- Alva, Walter, Christopher B. Donnan, Bill Ballenberg, and Ned Seidler. 1988. Richest Unlooted Tomb of a Moche Lord. *National Geographic* 174:510-56.
- Aronson, Sidney H. 1977. Bell's Electrical Toy: What's the Use? The Sociology of Early Telephone Usage. In *The Social Impact of the Telephone*. Ed. Ithiel de Sola Pool. Cambridge, MA: MIT Press, 15-40.
- Ascher, M., and R. Ascher. 1982. *Code of the Quipu: A Study in Media, Mathematics, and Culture*. Ann Arbor: University of Michigan Press.
- Ashby, W. Ross. 1956. *An Introduction to Cybernetics*. 7th ed. New York: Methuen.
- . 1981a. Connectance of Large Dynamic (Cybernetic) Systems: Critical Values for Stability. In *Mechanisms of Intelligence: Ross Ashby's Writings On Cybernetics*. 1st ed. Ed. Roger Conant. Seaside: Intersystems, 89-93.
- . 1981b. Effect of Controls On Stability. In *Mechanisms of Intelligence: Ross Ashby's Writings On Cybernetics*. 1st ed. Ed. Roger Conant. Seaside: Intersystems, 7-11.

- . 1981c. Every Good Regulator of a System Must Be a Model of That System. In *Mechanisms of Intelligence: Ross Ashby's Writings On Cybernetics*. 1st ed. Ed. Roger Conant. Seaside: Intersystems, 205-217.
- . 1981d. Requisite Variety and Its Implications for the Control of Complex Systems. In *Mechanisms of Intelligence: Ross Ashby's Writings On Cybernetics*. 1st ed. Ed. Roger Conant. Seaside: Intersystems, 187-203.
- Attali, Jacques, and Yves Stourdze. 1977. The Birth of the Telephone and Economic Crisis: The Slow Death of Monologue in French Society. In *The Social Impact of the Telephone*. Ed. Ithiel de Sola Pool. Cambridge, MA: MIT Press, 97-112.
- Ball, Johnson. 1973. *William Caslon, 1693-1766: The Ancestry, Life and Connections of England's Foremost Letter-Engraver and Type-Founder*. Kington: Roundwood Press.
- Bavelas, Alex. 1952. Communication Patterns in Problem-Solving Groups. In *Cybernetics: Circular Causal and Feedback Mechanisms in Biological and Social Systems*. Ed. Heinz Von Foerster. NY: Josiah Macy, Jr. Foundation, 1-44. Transactions of the eighth conference.
- Beniger, James R. 1986. *The Control Revolution: Technological and Economic Origins of the Information Society*. Cambridge, MA: Harvard University Press.
- Bernstein, Michael A. 1987. *The Great Depression: Delayed Recovery and Economic Change in America 1929-1939*. Cambridge, UK: Cambridge University Press.
- Berry, W. Turner, and Herbert Edmund Poole. 1966. *Annals of Printing: A Chronological Encyclopaedia from the Earliest Times to 1950*. London: Blandford.
- Bieseke, Megan. 1982. Aspects of !Kung Folklore. In *Kalahari Hunter-Gatherers: Studies of the !Kung San and Their Neighbors*. Eds. Richard B. Lee and Irvn DeVore. Cambridge, MA: Harvard University Press, 302-325.

- Binford, Lewis. 1978. *Nunamiut Ethnoarchaeology*. New York: Thames and Hudson.
- . 1983. *In Pursuit of the Past: Decoding the Archaeological Record*. New York: Thames and Hudson.
- Bloch, Marc Leopold Benjamin. 1953. *The Historian's Craft*. New York: Knopf. Putnam, Peter trans.
- . 1961. *Feudal Society*. Chicago: University of Chicago Press. Manyon, L. A. trans.
- Blurton-Jones, Nicholas, and Melvin J. Konner. 1982. ! Kung Knowledge of Animal Behavior (Or: The Proper Study of Mankind Is Animals). In *Kalahari Hunter-Gatherers: Studies of the !Kung San and Their Neighbors*. Eds. Richard B. Lee and Irven DeVore. Cambridge, MA: Harvard University Press, 325-349.
- Boettinger, Henry M. 1977. Our Sixth-And-A-Half Sense. In *The Social Impact of the Telephone*. Ed. Ithiel de Sola Pool. Cambridge, MA: MIT Press, 200-208.
- Boserup, E. 1965. *The Conditions of Agricultural Growth*. Chicago: Aldine.
- Bossy, John. 1967. The Character of Elizabethan Catholicism. In *Crisis in Europe: 1560 - 1660*. Ed. Trevor Aston. New York: Doubleday, 235-261.
- Boulding, Elizabeth. 1976. *The Underside of History*. Boulder: University of Colorado Press.
- Braudel, Fernand. 1972. *The Mediterranean and the Mediterranean World in the Age of Philippe II*. New York: Harper & Row. Reynolds, Sian trans.
- . 1977. *Afterthoughts On Material Civilization and Capitalism*. Baltimore: Johns Hopkins University Press. Ranum, Patricia M.
- . 1984. *Civilization and Capitalism, 15th-18th Century*. New York: Harper & Row.
- Braun, Rudolf. 1966. The Impact of Cottage Industry On an Agricultural Population. In *The Rise of Capitalism*. Ed. David S. Landes. New York: Mcmillan, 53-65.

- Briggs, Asa. 1977. *The Pleasure Telephone: A Chapter in the Prehistory of the Media*. In *The Social Impact of the Telephone*. Ed. Ithiel de Sola Pool. Cambridge, MA: MIT Press, 40-66.
- Brooks, Alison S., Diane E. Gelburd, and John E. Yellen. 1984. *Food Production and Culture Change Among the !Kung San: Implications for Prehistoric Research*. In *From Hunters to Farmers: The Causes and Consequences of Food Production in Africa*. Eds. J. Desmond Clark and Steven A. Brandt. Berkeley: University of California Press, 291-293.
- Brooks, John. 1977. *The First and Only Century of Telephone Literature*. In *The Social Impact of the Telephone*. Ed. Ithiel de Sola Pool. Cambridge, MA: MIT Press, 208-225.
- Canby, Thomas Y., Kerby Smith, and Roy Andersen. 1979. *Far-Flung Search for the First Americans*. *National Geographic* 156:330-65.
- Carneiro, R. 1970. *A Theory of the Origin of the State*. *Science* 169:733-38.
- Chandler, Alfred Dupont. 1977. *The Visible Hand : The Managerial Revolution in American Business*. Cambridge, MA.: Belknap Press.
- Chapelot, Jean, and Robert Fossier. 1985. *The Village and House in the Middle Ages*. English ed. Berkeley: University of California Press. Trans. Cleere, Henry.
- Chappell, Warren. 1980. *A Short History of the Printed Word*. Boston: D.R. Godine.
- Cherry, Colin. 1977. *The Telephone System: Creator of Mobility and Social Change*. In *The Social Impact of the Telephone*. Ed. Ithiel de Sola Pool. Cambridge, MA: MIT Press, 112-127.
- Christie, Lee S., R. Duncan Luce, and Josiah Macy Jr. 1952. *Communication and Learning in Task-Oriented Groups*. Cambridge, MA: MIT Research Laboratory of Electronics. Technical report 231.
- Claessen, H. J. M., and Peter Skalnik, eds. 1978. *The Early State*. The Hague: Mouton.

- eds. 1981. *The Study of the State*. The Hague: Mouton.
- Clark, J. Desmond, and Steven A. Brandt. 1984. An Introduction to an Introduction. In *From Hunters to Farmers: The Causes and Consequences of Food Production in Africa*. Eds. J. Desmond Clark and Steven A. Brandt. Berkeley: University of California Press, 1-5.
- Cochran, Thomas C. 1981. *Frontiers of Change: Early Industrialism in America*. Oxford: Oxford University Press.
- Cohen, Arthur M., and Warren G. Bennis. 1962. Predicting Organization in Changed Communication Networks. *Journal of Psychology* 54:391-416.
- Coleman, D. C. 1966. Industrial Growth and Industrial Revolutions. In *The Rise of Capitalism*. Ed. David S. Landes. New York: Mcmillan, 81-111.
- Conant, Roger, ed. 1981. *Mechanisms of Intelligence: Ross Ashby's Writings On Cybernetics*. Seaside: Intersystems.
- Cowgill, G. 1975. On Causes and Consequences of Ancient and Modern Population Changes. *American Anthropologist* 77:505-25.
- Cowgill, U. 1962. An Agricultural Study of the Southern Maya Lowlands. *American Anthropologist* 64:273-86.
- Curtis, Mark H. 1967. The Alienated Intellectuals of Early Stuart England. In *Crisis in Europe: 1560 - 1660*. Ed. Trevor Aston. New York: Doubleday, 309-332.
- Diamond, Jared M. 1989. Historic Extinction: A Rosetta Stone for Understanding Prehistoric Extinctions. In *Quaternary Extinctions: A Prehistoric Revolution*. Eds. Paul S. Martin and Richard G. Klein. Tuscon: Arizona University Press, 824-867.
- Diamond, Stanley. 1966. Introduction: Africa in the Perspective of Political Anthropology. In *The Transformation of East Africa: Studies in Political Anthropology*. Eds. Stanley Diamond and Fred Burke. New York: Basic books.

- Dilts, Marion May. 1941. *The Telephone in a Changing World*. Green, NY: Longmans.
- Dobb, Maurice. 1963. *Studies in the Development of Capitalism*. New York: International Publishers.
- . 1966. The "Great Depression". In *The Rise of Capitalism*. Ed. David S. Landes. New York: Mcmillan, 130-140.
- Dobb, Maurice Herbert. 1964. *Studies in the Development of Capitalism*. New York: International Publishers.
- Edmondson, William, ed. 1985. *The Age of Access, Information Technology and Social Revolution: Posthumous Papers of Colin Cherry*. London: Croom Helm.
- Einstein, Albert, and Leopold Infeld. 1938. *The Evolution of Physics*. New York: Simon & Schuster.
- Eisenstein, Elizabeth L. 1979. *The Printing Press As an Agent of Change : Communications and Cultural Transformations in Early Modern Europe / Elizabeth L. Eisenstein*. Cambridge, UK: Cambridge University Press.
- Elliott, John H. 1967. The Decline of Spain. In *Crisis in Europe: 1560 - 1660*. Ed. Trevor Aston. New York: Doubleday, 177-206.
- . 1978. Revolution and Continuity in Early Modern Europe. In *The General Crisis of the Seventeenth Century*. Eds. Geoffrey Parker and Lesley M. Smith. London: Routledge & Kegan Paul, 110-134.
- Febvre, Lucien, and H. J. Martin. 1976. *The Coming of the Book*. London UK: N.L.B. Gerard, David trans.
- Flannery, K., V. 1973. The Origins of Agriculture. *Annual Review of Anthropology* 2:271-310.
- Gailey, Christine Ward. 1987. *Kinship to Kingship: Gender Hierarchy and State Formation in the Tongan Islands*. Austin: Texas University Press.

- Gailey, Christine Ward, and Thomas Patterson. 1990. State Formation and Uneven Development. In *State and Society*. Eds. Barbara Bender, John Glendhill, and Mogens Larsen. London UK: Allen and Unwin.
- Galambos, Louis, and Joseph Pratt. 1988. *The Rise of the Corporate Commonwealth: United States Business and Public Policy in the Twentieth Century*. New York: Basic Books.
- Galbraith, J. Kenneth. 1972. *The Great Crash 1929*. 3rd ed. Boston MA: Houghton Mifflin.
- Gamble, Clive. 1987. *The Paleolithic Settlement of Europe*. Cambridge, UK: Cambridge University Press.
- Gerschenkron, Alexander. 1966. Economic Backwardness in Historical Perspective. In *The Rise of Capitalism*. Ed. David S. Landes. New York: Mcmillan, 111-130.
- Gottmann, Jean. 1977. Megalopolis and Antipolis: The Telephone and the Structure of the City. In *The Social Impact of the Telephone*. Ed. Ithiel de Sola Pool. Cambridge, MA: MIT Press, 303-318.
- Goubert, Pierre. 1967. The French Peasantry of the Seventeenth Century: A Regional Example. In *Crisis in Europe: 1560 - 1660*. Ed. Trevor Aston. New York: Doubleday, 150-177.
- Gould, Carol C. 1980. *Marx's Social Ontology: Individuality and Community in Marx's Theory of Social Reality*. Cambridge, MA: MIT press.
- Grayson, Donald K. 1989. Explaining the Pleistocene Extinctions: Thoughts On the Structure of the Debate. In *Quaternary Extinctions: A Prehistoric Revolution*. Eds. Paul S. Martin and Richard G. Klein. Tuscon: Arizona University Press, 807-824.
- Guenther, Mathias G. 1982. From Hunters to Squatters: Social and Cultural Change Among the Farm San of Ghanzi, Botswana. In *Kalahari Hunter-Gatherers: Studies of the !Kung San and Their Neighbors*. Eds. Richard B. Lee and Irven DeVore. Cambridge, MA: Harvard University Press, 120-134.

- Gunderson, Gerald. 1989. *The Wealth Creators : An Entrepreneurial History of the United States*. New York: Dutton.
- Hamilton, E. J. 1934. *American Treasure and the Price Revolution*. Cambridge, MA: Harvard University Press.
- Handover, P. M. 1960. *Printing in London: From 1476 to Modern Times*. Cambridge, MA: Harvard University Press.
- Harris, Marvin. 1983. *Cultural Materialism: The Struggle for a Science of Culture*. New York: Random House.
- Hays, T. R. 1984. A Reappraisal of the Egyptian Predynastic. In *From Hunters to Farmers: The Causes and Consequences of Food Production in Africa*. Eds. J. Desmond Clark and Steven A. Brandt. Berkeley: University of California Press, 57-65.
- Hibbard, Angus. 1941. *Hello Goodbye*. New York: A. C. McClurg & Co.
- Hill, Christopher. 1966. Protestantism and the Rise of Capitalism. In *The Rise of Capitalism*. Ed. David S. Landes. New York: McMillan, 41-53.
- . 1967. Introduction. In *Crisis in Europe: 1560 - 1660*. Ed. Trevor Aston. New York: Doubleday, 1-5.
- Hobsbawm, E. J. 1967. The Crisis of the Seventeenth Century. In *Crisis in Europe: 1560 - 1660*. Ed. Trevor Aston. New York: Doubleday, 5-63.
- Holling, C. S. 1959. The Components of Predation As Revealed By a Study of Small-Mammal Predation of the European Pine Sawfly. *Canadian Entomologist* 91:293-320.
- Howell, Nancy. 1984. Perspectives and Prospects for Understanding the Effects of Population On the Causes and Consequences of Food Production. In *From Hunters to Farmers: The Causes and Consequences of Food Production in Africa*. Eds. J. Desmond Clark and Steven A. Brandt. Berkeley: University of California Press, 351-361.

- Huffaker, C. B. 1958. Experimental Studies On Predation: Dispersion Factors and Predator-Prey Oscillations. *Hilgardia* 27:343-83.
- Hunt, Leigh. 1967. *Leigh Hunt's London Journal. To Assist the Inquiring, Animate the Struggling, and Sympathize With All*. New York: AMS Press.
- Jackson, Holbrook. 1970. *The Printing of Books*. Freeport: Books for Libraries Press.
- Jones, G. D., and R. R. Kautz, eds. 1981. *The Transition to Statehood in the New World*. Cambridge, UK: Cambridge University Press.
- Katz, Claudio J. 1989. *From Feudalism to Capitalism: Marxian Theories of Class Struggle and Social Change*. New York: Greenwood Press.
- Keller, Susan. 1977. The Telephone in New (and Old) Communities. In *The Social Impact of the Telephone*. Ed. Ithiel de Sola Pool. Cambridge, MA: MIT Press, 281-299.
- Kindleberger, Charles P. 1986. *The World in Depression 1929-1939*. Berkeley: University of California Press.
- Kirkland, Edward C. 1948. *The Transportation Revolution*. Cambridge, MA: Harvard University Press.
- Klemm, Fredrich. 1959. *A History of Western Technology*. New York: Charles Scribner's Sons.
- Landes, David S. 1966a. Introduction. In *The Rise of Capitalism*. Ed. David S. Landes. New York: McMillan, 1-26.
- ed. 1966b. *The Rise of Capitalism*. New York: MacMillan.
- . 1966c. The Structure of Enterprise in the Nineteenth Century. In *The Rise of Capitalism*. Ed. David S. Landes. New York: McMillan, 99-111.
- Lane, Fredrick C. 1953. Family Partnership and Joint Ventures in the Venetian Republic. In *Enterprise and Secular Change*. Eds. Fredrick C. Lane and Jelle C. Riemersma. Homewood IL: Richard D Irwin, 86-101.

- Lanning, E. P. 1967. *Peru Before the Incas*. Englewood Cliffs: Prentice Hall.
- Leavitt, Harold J. 1952. Collective Problem-Solving in Small Groups. In *Readings in Social Psychology*. Ed. Society for the psychological study of social issues. NY: Henry Holt & Co, 108-125.
- Lee, Richard B. 1984. *The Dobe !Kung*. Case studies in cultural anthropology, ed. George Spindler and Louise Spindler. New York: Holt, Rinehart and Winston.
- Lester, David. 1977. The Use of the Telephone in Counseling and Crisis Intervention. In *The Social Impact of the Telephone*. Ed. Ithiel de Sola Pool. Cambridge, MA: MIT Press, 454-473.
- Livesay, Harold C. 1979. *American Made: Men Who Shaped the American Economy*. Boston: Little Brown.
- Lubell, David. 1984. Paleoenvironments and Epi-Paleolithic Economies in the Maghreb (Ca. 20,000 to 5000 B.P.). In *From Hunters to Farmers: The Causes and Consequences of Food Production in Africa*. Eds. J. Desmond Clark and Steven A. Brandt. Berkeley: University of California Press, 37-41.
- Maddox, Brenda. 1977. Women and the Switchboard. In *The Social Impact of the Telephone*. Ed. Ithiel de Sola Pool. Cambridge, MA: MIT Press, 262-281.
- Maddox, Harry Alfred. 1923. *Printing, Its History, Practice, and Progress*. London: Sir I. Pitman & Sons.
- Manning, Brian. 1967. The Nobles, the People, and the Constitution. In *Crisis in Europe: 1560 - 1660*. Ed. Trevor Aston. New York: Doubleday, 261-285.
- Marshack, Alexander. 1988. An Ice Age Ancestor? *National Geographic* 174:478-82.
- Marshall, Larry G. 1989. Who Killed Cock Robin? An Investigation of the Extinction Controversy. In *Quaternary Extinctions: A Prehistoric Revolution*. Eds. Paul S. Martin and Richard G. Klein. Tucson: Arizona University Press, 785-807.

- Marshall, Lorna. 1982. Sharing, Talking and Giving: Relief of Social Tensions Among the !Kung. In *Kalahari Hunter-Gatherers: Studies of the !Kung San and Their Neighbors*. Eds. Richard B. Lee and Irven DeVore. Cambridge, MA: Harvard University Press, 349-372.
- Martin, Paul S. 1989. Prehistoric Overkill: The Global Model. In *Quaternary Extinctions: A Prehistoric Revolution*. Eds. Paul S. Martin and Richard G. Klein. Tucson: Arizona University Press, 354-404.
- Martin, Paul S., and Richard G. Klein, eds. 1989. *Quaternary Extinctions: A Prehistoric Revolution*. Tucson: University of Arizona.
- Martin, Paul S., and Haldine E. Wright Jr., eds. 1967. *Pleistocene Extinctions*. New Haven: Yale University Press.
- Maruyama, Magoroh. 1968. The Second Cybernetics: Deviation-Amplifying Mutual Causal Processes. In *Modern Systems Research*. Ed. Walter Buckley. NY: Aldine.
- Marx, Karl. 1970a. *Capital*. New York: International publishers.
- . 1970b. *A Contribution to the Critique of Political Economy*. New York: International publishers.
- Marx, Karl, and Fredrick Engels. 1948. *The Communist Manifesto*. New York: International publishers.
- Maturana, Humberto R., and Francisco J. Varela. 1980. *Autopoiesis and Cognition: The Realization of the Living*. Boston studies in the philosophy of science, ed. Robert S. Cohen and Marx W. Wartofsky, 42. Dordrecht, Holland: D. Reidel Publishing.
- May, R. M. 1972. Limit Cycles in Predator-Prey Communities. *Science* 177:900-904.
- Mayer, Martin. 1977. The Telephone and the Use of Time. In *The Social Impact of the Telephone*. Ed. Ithiel de Sola Pool. Cambridge, MA: MIT Press, 225-246.

- McKendrick, Neil. 1966. Josiah Wedgewood and Factory Discipline. In *The Rise of Capitalism*. Ed. David S. Landes. New York: Mcmillan, 65-81.
- McNeill, William. 1963. *The Rise of the West: A History of the Human Community*. Chicago: Chicago University Press.
- Mehring, Peter J., and Warren Morgan. 1988. Weapons Cache of Ancient Americans. *National Geographic* 174: 500-504.
- Miskimin, Harry A. 1969. *The Economy of Early Renaissance Europe, 1300-1460*. Cambridge, UK: Cambridge University Press.
- Modelski, George L., ed. 1987. *Exploring Long Cycles*. Boulder: L. Rienner Publishers.
- Moote, A. Lloyd. 1978. The Preconditions of Revolution in Early Modern Europe: Did They Really Exist? In *The General Crisis of the Seventeenth Century*. Eds. Geoffrey Parker and Lesley M. Smith. London: Routledge & Kegan Paul, 134-165.
- Moran, James. 1973. *Printing Presses; History and Development from the Fifteenth Century to Modern Times*. Berkeley: University of California Press.
- Mousnier, Roland, J. H. Elliott, and H. R. Trevor-Roper. 1967. Trevor-Roper's 'General Crisis': Symposium. In *Crisis in Europe: 1560 - 1660*. Ed. Trevor Aston. New York: Doubleday, 103-124.
- Moyer, Alan J. 1977. Urban Growth and the Development of the Telephone: Some Relationships At the Turn of the Century. In *The Social Impact of the Telephone*. Ed. Ithiel de Sola Pool. Cambridge, MA: MIT Press, 342-371.
- Needham, Joseph. 1956. Mathematics and Science in China and the West. *Science and Society* 1956:343.
- . 1969. Science and Society East and West. In *The Grand Titration*. Ed. Joseph Needham. London UK: George Allen & Unwin, 190.
- Nelson, Harry, and Robert Jurmain. 1988. *Introduction to Physical Anthropology*. 4th ed. St Paul: West.

- North, Douglas C. 1981. *Structure and Change in Economic History*. New York: W. W. Norton.
- North, Douglass C., and Robert Paul Thomas. 1973. *The Rise of the Western World: A New Economic History*. Cambridge, UK: Cambridge Univ Press.
- Oswald, John Clyde. 1928. *A History of Printing, Its Development Through Five Hundred Years*. New York: D. Appleton and company.
- Parker, Geoffrey. 1978. The Dutch Revolt and the Polarization of International Politics. In *The General Crisis of the Seventeenth Century*. Eds. Geoffrey Parker and Lesley M. Smith. London: Routledge & Kegan Paul, 57-83.
- Parker, Geoffrey, and Lesley M. Smith. 1978. Introduction. In *The General Crisis of the Seventeenth Century*. Eds. Geoffrey Parker and Lesley M. Smith. London: Routledge & Kegan Paul, 1-26.
- Perry, Charles R. 1977. The British Experience 1876-1912: The Impact of the Telephone During the Years of Delay. In *The Social Impact of the Telephone*. Ed. Ithiel de Sola Pool. Cambridge, MA: MIT Press, 69-97.
- Piddock, Stuart. 1965. The Potlatch System of the Southern Kwakiutl: A New Perspective. *Southwestern Journal of Anthropology* 21:244-64.
- Pierce, John. 1977. The Telephone and Society in the Past 100 Years. In *The Social Impact of the Telephone*. Ed. Ithiel de Sola Pool. Cambridge, MA: MIT Press, 159-197.
- Pirenne, Henri. 1925. *Medieval Cities, Their Origins and the Revival of Trade*. Princeton: Princeton University Press.
- . 1937. *Economic and Social History of Medieval Europe*. New York: Harcourt, Brace and World.
- Pool, Ithiel de Sola. 1977a. Alternative Paths of Development: The Early Years. In *The Social Impact of the Telephone*. Ed. Ithiel de Sola Pool. Cambridge, MA: MIT Press, 11-12.

- . 1977b. Introduction. In *The Social Impact of the Telephone*. Ed. Ithiel de Sola Pool. Cambridge, MA: MIT Press, 1-11.
- . 1977c. Social Uses of the Telephone. In *The Social Impact of the Telephone*. Ed. Ithiel de Sola Pool. Cambridge, MA: MIT Press, 451-454.
- . 1977d. The Telephone and Human Interaction. In *The Social Impact of the Telephone*. Ed. Ithiel de Sola Pool. Cambridge, MA: MIT Press, 371-374.
- . 1977e. The Telephone and the City. In *The Social Impact of the Telephone*. Ed. Ithiel de Sola Pool. Cambridge, MA: MIT Press, 299-303.
- Pool, Ithiel de Sola, Craig Decker, Stephen Dizard, Kay Israel, Pamela Rubin, and Barry Weinstein. 1977. Foresight and Hindsight: The Case of the Telephone. In *The Social Impact of the Telephone*. Ed. Ithiel de Sola Pool. Cambridge, MA: MIT Press, 127-158.
- Postan, M. M. 1972. *The Medieval Economy and Society*. London: Weidenfeld and Nicolson.
- Postan, Michael M., and H. J. Habakkuk. 1966. *The Cambridge Economic History of Europe*. Cambridge, UK: Cambridge University Press.
- Postan, Michael Moissey. 1973a. *The Medieval Economy and Society; an Economic History of Britain, 1100-1500*. Berkeley: University of California Press.
- . 1973b. *Medieval Trade and Finance*. Cambridge, UK: Cambridge University Press.
- Postman, Neil. 1982. *The Disappearance of Childhood*. New York: Laurel Press.
- . 1985. *Amusing Ourselves to Death : Public Discourse in the Age of Show Business*. New York: Viking.
- Pottinger, David Thomas. 1971. *Printers and Printing*. Freeport: Books for Libraries Press.
- Putman, John J., Sisse Brimberg, and Ira Block. 1988. In Search of Modern Humans. *National Geographic* 174:438-78.

- Rao, Paladugu, V. 1977. Telephone and Instructional Communications. In *The Social Impact of the Telephone*. Ed. Ithiel de Sola Pool. Cambridge, MA: MIT Press, 473-487.
- Reich, Leonard S. 1985. *The Making of American Industrial Research: Science and Business At GE and Bell, 1876-1926*. Cambridge, UK: Cambridge University Press.
- Reid, A. A. L. 1977. Comparing Telephone With Face-To-Face Contact. In *The Social Impact of the Telephone*. Ed. Ithiel de Sola Pool. Cambridge, MA: MIT Press, 386-415.
- Renfrew, Colin. 1979. *Before Civilization: The Radiocarbon Revolution and Prehistoric Europe*. Cambridge UK: Cambridge University Press.
- Rigaud, Jean-Phillipe, Sisse Brimberg, and Norbert Aujoulat. 1988. Treasures of Lascaux Cave. *National Geographic* 174:482-500.
- Roberts, Michael. 1967. Queen Christina and the General Crisis of the Seventeenth Century. In *Crisis in Europe: 1560 - 1660*. Ed. Trevor Aston. New York: Doubleday, 206-235.
- Romano, Ruggiero. 1978. Between the Sixteenth and Seventeenth Centuries: The Economic Crisis of 1619-22. In *The General Crisis of the Seventeenth Century*. Eds. Geoffrey Parker and Lesley M. Smith. London: Routledge & Kegan Paul, 165-226.
- Rosenberg, Nathan, and L. E. Birdzell Jr. 1986. *How the West Grew Rich: The Economic Transformation of the Industrial World*. New York: Basic Books.
- Rostow, W. W. 1960. *The Stages of Economic Growth, a Non-Communist Manifesto*. Cambridge, UK: Cambridge University Press.
- . 1975. *How It All Began; Origins of the Modern Economy*. New York: McGraw-Hill.
- . 1978. *The World Economy : History and Prospect*. Austin: University of Texas Press.
- Russell, J. C. 1948. *British Medieval Population*. Albuquerque: University of New Mexico Press.

- Schama, Simon. 1987. *The Embarrassment of Riches : An Interpretation of Dutch Culture in the Golden Age*. New York: Random House.
- Schegloff, Emanuel A. 1977. Identification and Recognition in Interactional Openings. In *The Social Impact of the Telephone*. Ed. Ithiel de Sola Pool. Cambridge, MA: MIT Press, 415-451.
- Schmookler, Andrew Bard. 1984. *The Parable of the Tribes: The Problem of Power in Social Evolution*. Berkeley: University of California Press.
- Schoffer, Ivo. 1978. Did Holland's Golden Age Coincide With a Period of Crisis? In *The General Crisis of the Seventeenth Century*. Eds. Geoffrey Parker and Lesley M. Smith. London: Routledge & Kegan Paul, 83-110.
- Schofield, Roger S., and E. Anthony Wrigley, eds. 1986. *Population and Economy : Population and History from the Traditional to the Modern World*. Cambridge, UK: Cambridge University Press.
- Schumpeter, Joseph Alois. 1950. *Capitalism, Socialism, and Democracy*. New York: Harper.
- . 1951. *Imperialism and Social Classes*. Translated By Heinz Norden; Edited and With an Introd. By Paul M. Sweezy. New York: A. M. Kelley.
- Service, Ellman. 1962. *Primitive Social Organization*. New York: Random House.
- Shannon, Claude E., and Warren Weaver. 1963. *The Mathematical Theory of Communication*. Urbana: University of Illinois.
- Shaw, Marvin E. 1978. Communications Networks Fourteen Years Later. In *Group Processes: Papers from Advances in Experimental Social Psychology*. Ed. Leonard Berkowitz. NY: Academic Press, 351-361.
- Shaw, William H. 1978. *Marx's Theory of History*. Stanford, CA: Stanford University Press.
- Smith, Adam. 1976. *An Inquiry into the Nature and Causes of the Wealth of Nations*. New York: Oxford University Press.

- Smith, Andrew B. 1984. Origins of the Neolithic in the Sahara. In *From Hunters to Farmers: The Causes and Consequences of Food Production in Africa*. Eds. J. Desmond Clark and Steven A. Brandt. Berkeley: University of California Press, 84-93.
- Sombart, Werner. 1953. Medieval and Modern Commercial Enterprise. In *Enterprise and Secular Change*. Eds. Fredrick C. Lane and Jelle C. Riemersma. Homewood IL: Richard D. Irwin, 86-101.
- . 1967. *The Quintessence of Capitalism; a Study of the History and Psychology of the Modern Business Man*. New York: H. Fertig. Epstein, M. trans.
- . 1969. *A New Social Philosophy*. New York: Greenwood Press. Geiser, Karl F. (trans.).
- Soros, George. 1988. *The Alchemy of Finance*. New York: Touchstone Books.
- Steensgaard, Niels. 1978. The Seventeenth Century Crisis. In *The General Crisis of the Seventeenth Century*. Eds. Geoffrey Parker and Lesley M. Smith. London: Routledge & Kegan Paul, 26-57.
- Steinberg, Sigfrid H. 1974. *Five Hundred Years of Printing*. Baltimore: Penguin Books.
- Stemler, Ann. 1984. The Transition from Food Collecting to Food Production in Northern Africa. In *From Hunters to Farmers: The Causes and Consequences of Food Production in Africa*. Eds. J. Desmond Clark and Steven A. Brandt. Berkeley: University of California Press, 127-132.
- Suttles, Wayne. 1960. Affinal Ties, Subsistence and Prestige Among the Coast Salish. *American Anthropologist* 62:296-305.
- Sweezy, Paul, and Paul Malor. 1976. *The Transition from Feudalism to Capitalism*. London: N.L.B.
- Sweezy, Paul Marlor. 1956. *The Theory of Capitalist Development; Principles of Marxian Political Economy*. New York: Monthly Review Press.

- Tanaka, Jiro. 1982. Subsistence Ecology of Central Kalahari San. In *Kalahari Hunter-Gatherers: Studies of the !Kung San and Their Neighbors*. Eds. Richard B. Lee and Irven DeVore. Cambridge, MA: Harvard University Press, 98-120.
- Thorngren, Bertil. 1977. Silent Actors: Communication Networks for Development. In *The Social Impact of the Telephone*. Ed. Ithiel de Sola Pool. Cambridge, MA: MIT Press, 374-386.
- Trevor-Roper, H. R. 1967. The General Crisis of the Seventeenth Century. In *Crisis in Europe: 1560 - 1660*. Ed. Trevor Aston. New York: Doubleday, 5-63.
- Trigger, Bruce G. 1982. The Rise of Civilization in Egypt. In *The Cambridge History of Africa*. Ed. J. D. Clark. Vol. 1. Cambridge, UK: Cambridge University Press.
- Truswell, A. Stewart, and John D. L. Hansen. 1982. Medical Research Among the !Kung. In *Kalahari Hunter-Gatherers: Studies of the !Kung San and Their Neighbors*. Eds. Richard B. Lee and Irven DeVore. Cambridge, MA: Harvard University Press, 166-195.
- Vilar, Pierre. 1966. Problems of the Formation of Capitalism. In *The Rise of Capitalism*. Ed. David S. Landes. New York: McMillan, 26-41.
- Von Foerster, Heinz. 1984. Principles of Self-Organization - In a Socio-Managerial Context. In *Self-Organization and Management of Social Systems: Insights, Promises, Doubts, and Questions*. Eds. H. Ulrich and G. J. B. Probst. NY: Springer Verlag, 2-24.
- Washburn, Sherwood L. 1982. Foreward. In *Kalahari Hunter-Gatherers: Studies of the !Kung San and Their Neighbors*. Eds. Richard B. Lee and Irven DeVore. Cambridge, MA: Harvard University Press, ix-xv.
- Ways, Max. 1966. The Postwar Advance of the Five Hundred Million. In *The Rise of Capitalism*. Ed. David S. Landes. New York: McMillan, 140-150.
- Weber, Max. 1947. *The Theory of Social and Economic Organization*. New York: Free Press. Henderson, A. M. & Parsons, T. trans.

- Weiss, Mark L., and Alan E. Mann. 1990. *Human Biology and Behavior: An Anthropological Perspective*. 5th ed. Glenview, IL: Scott Foresman.
- Weissleder, W. 1978. *The Nomadic Alternative: Models and Models of Interaction in the African-Asian Deserts and Steppes*. The Hague: Mouton.
- Wenke, Robert J. 1984. *Patterns in Prehistory: Humankind's First Three Million Years*. 2nd ed. New York: Oxford University Press.
- White, Leslie. 1949. *The Science of Culture*. New York: Grove Press.
- White, Lynn Townsend, Jr. 1962. *Medieval Technology and Social Change*. London: Clarendon Press.
- White, Lynn Townsend, Jr. 1978. *Medieval Religion and Technology : Collected Essays*. Berkeley: University of California Press.
- Wiebe, Robert H. 1967. *The Search for Order: 1877-1920*. New York: Hill and Wang.
- Winship, George Parker. 1940. *Printing in the Fifteenth Century*. Philadelphia: University of Pennsylvania Press.
- Woodward, David, ed. 1975. *Five Centuries of Map Printing*. Chicago: University of Chicago Press.
- Wrigley, Edward Anthony. 1969. *Population and History*. New York: McGraw-Hill.
- Wurtzel, Alan H., and Colin Turner. 1977. Latent Functions of the Telephone: What Missing the Extension Means. In *The Social Impact of the Telephone*. Ed. Ithiel de Sola Pool. Cambridge, MA: MIT Press, 246-262.
- Wymer, John. 1982. *The Paleolithic Age*. New York: St. Martin's Press.
- Yellen, John E. 1982. Settlement Patterns of the !Kung: An Archaeological Perspective. In *Kalahari Hunter-Gatherers: Studies of the !Kung San and Their Neighbors*. Eds. Richard B. Lee and Irven DeVore. Cambridge, MA: Harvard University Press, 47-73.

Yellen, John E., and Richard B. Lee. 1982. The Dobe-/Du/Da Environment: Background to a Hunting and Gathering Way of Life. In *Kalahari Hunter-Gatherers: Studies of the !Kung San and Their Neighbors*. Eds. Richard B. Lee and Irven DeVore. Cambridge, MA: Harvard University Press, 27-47.

APPENDIX A

NATURAL UNIT SIZE INCREASED: INCREASED COMMUNICATIONS AND ABILITY TO MODEL

SPEECH

Before

Cooperation amongst group members was implicit and occurred because of common intent and geographical proximity

After

Cooperation became an explicit social and productive value. People explicitly cooperated during the activities of subsistence and shared the information and goods which resulted from those activities. These values were taught and mandated by the spoken tradition of the culture.

Model

Stories, songs and myths function to both inform and to enforce cooperation and sharing. The social and economic group was produced and defined in the explicit sharing of goods and values through speech.

WRITING (quipu, cuneiform, icon and alphabet systems)

Before

Accumulation and distribution of goods based on kinship. Possible problems with "free riders" who benefit without contributing are controlled by implicit social sanction and small group size. Everyone knows who works and who is lazy. This keeps group membership small.

After

Social membership and class distinctions become alienated, rationalized and hierarchically organized. Allocation of goods is based on how class membership is defined.

Model

The notion of inventory becomes alienated from the activities of daily life because symbol making made it possible to count in puts and out flows. This allows the notion of membership to be defined as those who contribute. Membership can expand because it is possible to track members contributions and control the allocation of goods. This solves the "free rider problem", and allows the system to expand beyond the limit of the kin group.

PRINTING PRESS**Before**

Production of goods done in the social unit. Master, journeymen, and apprentices were in an age and status relationship. There was no distinction between activities of production of goods and the activities of daily life. People learned their trades in the same way they learned their language, as part of their life experience. There was no distinction between the person and her skills. The production group was limited to those who lived together. Information was limited to what could be remembered and experienced.

After

Production activities emerged as distinct from other activities of daily life. They emerged as separate from social relationships. This allowed these processes to be rationalized and organized outside the limit of the social group. The "putting out" system of production and the purchase of labor as a commodity emerged.

Model

The distinction of production as a process became alienated through the use of book keeping. The

craftsperson knew she paid for raw materials and that she sold goods, for her books to balance she had to account for the bit in between. The "bit in between" became labor. This allowed the activities related to production to become distinct from the other activities of daily life. They could then be seen as separate from the person of the craftsperson as a social entity and be paid for like raw material. The increase in literacy allowed credentials to be written so it was no longer necessary for an employer to know the employee personally. This allowed the size of the production system to expand beyond the size of the social group.

TELEGRAPH/TELEPHONE

Before

Activities of management are implicit in the person of the owner of the business unit. Managers are part of the social and often kin group of the owner. The distinction between labor and management functions like a class or social relation. All laborers are expected to take orders from all managers - communication channels are not explicit.

After

Lines of communication and organization are explicit. Business becomes rationalized and hierarchically organized. Communication has become alienated and is seen to run along specified channels which are based on functional relationships rather than geographical or social relationships.

Management becomes a professionalized - a learnable set of skills - rather than being intrinsic to membership in the kin group of the business owner.

Model

The existence of a formal network of communications channels alienated communication as a management process.

The introduction of the organizational chart in the communications industries began the restriction of lines of communication to organizational units. This

allowed the organizational units to specialize and streamline their activities.

COMPUTER

Before

The telegraph/telephone alienated the communications aspect of management practice leaving the decision making aspect of management intrinsic to the personal skill of the manager.

After

?? Complex decision criteria become alienated. ??

?? Control in many aspects and on many levels becomes alienated allowing more responsive systems of all kinds. ??

?? Notions of dynamical structure allows intellectual and scientific breakthroughs in many fields. ??

Model

Economic and accounting models, linear programming, decision trees and now expert systems are alienating the criteria for complex decision making.

Control systems engineering and automation alienate the processes of production from the intervention as well as the person of the laborer. Improved inventory management allows rapid response to replace standard inventory.

Complex evolutionary models allow feedback processes to improve quality to be designed instead of being seen as haphazard or a matter of luck. Economic, organizational, natural, and cultural systems can be seen to have the similar dynamic structures.

APPENDIX B

DEFINITIONS: REDUNDANCY AND CONNECTANCE

REDUNDANCY

Constraint (Ashby, 1958)

Ashby equates the notion of redundancy to the notion of constraint.

Constraint exists to the degree that the variety observed is less than the total possible variety. Ashby uses the example that the total variety of human gender is two, the gender variety of a boys' school is one - the variety is constrained - it is less than the total variety possible.

Applying this notion to the example of the craftsperson we could say that the relationship between the craftsperson and her apprentices was more constrained after the press than before the press.

Before the press the relationship between the craftsperson and the apprentice was social and geographical as well as a relationship for the purpose of production. After the press the relationship was more constrained, it was only a relationship for the purpose of production.

Ashby uses the notion of redundancy as constraint from an information theory perspective where there is an implied advantage to conserving channel capacity.

He states that where constraint exists advantage can be taken of it (Introduction to Cybernetics).

This suggests the following question: If the relationship between the craftsperson and her apprentices became more constrained what use was made of the increased channel capacity?

This leads to the second definition of redundancy:

Extra structures which create stability

The craftsperson used her increased channel capacity to hire and monitor many apprentices who became, in effect, standard, hired, production units rather than true apprentices.

These extra units of production hired by the craftsperson, kept the flow of goods stable. This type of redundancy is related to the growth of the economic system.

In addition, this definition of redundancy - extra structures which create stability - suggests that the social unit was more stable in pre-press times since it was more redundant than in post-press time. It was a geographical association of people who lived together and unit of production as well as a social unit.

The production process was subordinate to the social unit in pre-press economies and that the social unit was subordinate to production in post-press economies.

What we see as an increase in redundancy in the units related to production is actually a shift in emphasis. It is important to realize that an increase in redundancy, which we identify as keeping the relationship to production stable is a decrease in redundancy keeping other relations stable.

This implies that if we wish to make basic changes in a system we need to reduce the redundancy of structures which keep unwanted relationships stable and, increase the redundancy of desirable relationships.

CONNECTANCE

We can model an economic system as a group of individuals each one of whom takes stuff from the person ahead of her, does something to the stuff, and then passes it on. Each pass is a connection.

If the system is small enough for each of the members to see each of the other members the group can regulate their activities so that the stuff is passed smoothly - regulation is in the realm of unconscious behavior.

As the group gets bigger and bigger more and more connections are added and it gets harder and harder to keep

things moving smoothly because there are more and more chances of some problem occurring at one of the stations which then effects the whole group.

An increase in connectance increases the likelihood of instability. (Ashby, 1981, Gardner & Ashby, 1970, Von Foerster, et al, 1962)

The way to avoid instability is to increase redundancy.

The group can continue to grow by adding more connections by adding a regulatory layer - music or the beat of a drum - to keep the timing. Regulation of the system has become explicit. This is an example of redundancy of communications. It is regulation by a centralized authority.

As the system gets bigger and conveyor belts are used to pass around the stuff, then any hitch at any of the stations would result in an Abbott and Costello type of pile up of stuff.

The centralized authority may increase the redundancy of the central communications channels by having supervisors, and overseers of the supervisors - redundancy of design.

At some point centralized regulation of the timing of the system breaks down. Then the system either breaks down or stops growing. For the system to continue to grow it is necessary for control to pass to the individual at each node or station in the network.

An individual can insure the stability of her station if she can continue to pass stuff. This can occur if she increases the redundancy of the relationships she needs to continue.

She can build up a stock pile of material so that she is buffered against instability "up stream" - redundancy of material (inventory) or she may identify more than one source of material, and more than one individual to give material to - redundancy of material (alternate sources).

She may make a deal with her neighbors to shout if there is a hitch so she will be prepared - redundancy of communication. She may clone herself such that one of the clones is just in charge of taking things off, one is in charge of doing the something, and one is in charge of putting things on the next belt - redundancy of design.

Thus, through the action of the individual, acting locally, redundancy in the system increases and allows the size and the complexity of the system as a whole to increase.

In terms of economies or organizations the most difficult shifts in control are between centralized control and control by the individual stations and between implicit and explicit control by either the central authority or the individual.

This is because of the existing redundancy which keeps the old structure stable. (see above)

APPENDIX C

REDUNDANCY AND CONNECTANCE: CAUSE OF SYSTEMS GROWTH ASSOCIATED WITH INFORMATION TECHNOLOGY

SPEECH

Redundancy

Verbal models were shared through speech. Band members could decide on strategy for a hunt and develop signals to increase efficiency - redundancy of channel/communication.

Experiments with new gathered or hunted food could be communicated verbally - redundancy of material.

Connectance

Cooperative effort increased the efficiency of the exploitation of existing sources of food supply - increased flow through existing connections. identification of additional sources of food -increase in the number of connections.

WRITING

Redundancy

Models of inventory, based on symbols, allowed more goods to be tracked - redundancy of material.

Written symbols could be transported and given to others - redundancy of channel.

Connectance

Each official tracking inventory could oversee more contributions - increased flow through existing connections. More units could be administered over an increased geographical distance - increase in the number of connections.

PRINTING PRESS**Redundancy****Book keeping models**

Inventory control - redundancy of material.

Alienation, disaggregation, standardization, and general application of the production process - redundancy of design

Management emerges as an activity - redundancy of channel/communications.

Increased in written communications

Identification of geographically distant sources or markets - redundancy of material

Administration of more geographically separated units -redundancy of channel/communication

Connectance

Improved inventory and administration of existing units - increased flow through existing connections.

Identification of new sources and markets - increase in the number of connections

Design of new units of production - increase in the number of connections

TELEGRAPH/TELEPHONE**Redundancy**

Model of communications flow allowed the communication structure to be alienated, disaggregated standardized and generalized.

This resulted in the design of more hierarchically organized, rationalized units - redundancy of design

It also specified the communication structure which, by eliminating noise, made communications more efficient - redundancy of channel/communications

Increased communications

Increased the speed and geographical range of communications allowing administration of larger and larger units - redundancy of channel

Better materials monitoring due to faster communications between suppliers and manufacturers and between inventory and other units - redundancy of material

Identification of new markets and suppliers - redundancy of material

Increase in the turn around time of interactive communications allowed better monitoring and a shorter feedback loop - redundancy of channel, redundancy of design

Connectance

Redundancy of design increases the number of connections

The elimination of noise increases the efficiency of existing connections.

Administration of more units, inventory, suppliers and markets increases the number of connections

Better feedback loops increases the efficiency of existing connections.

COMPUTER**Redundancy**

Specific examples are too numerous - modeling creates redundancy of design in decision makers, manufacturing units, robotics.

Communications speeds efficiency by reducing noise in inventory - JIT, and improved feedback aids in better design and evolving quality.

(Note - Just In Time inventory systems allow for a reduction in material redundancy because of an increase in the redundancy of channel)

Connectance

Design of new units is an increase in connections

Reduction of noise is improved efficiency of existing connections

Opening the organizational boundaries so that the customer becomes part of the quality design process is an increase in connection